

# SUPERO<sup>®</sup>

SUPERSERVER

1027GR-72RT2+

1027GR-72R2+

1027GR-TRT2+

1027GR-TR2+

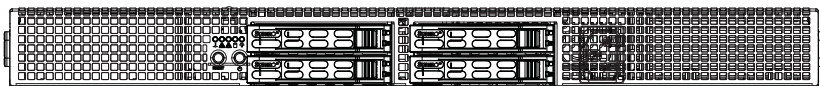

USER'S MANUAL

Revision 1.0

The information in this User's Manual has been carefully reviewed and is believed to be accurate. The vendor assumes no responsibility for any inaccuracies that may be contained in this document, makes no commitment to update or to keep current the information in this manual, or to notify any person or organization of the updates. **Please Note: For the most up-to-date version of this manual, please see our web site at [www.supermicro.com](http://www.supermicro.com).**

Super Micro Computer, Inc. ("Supermicro") reserves the right to make changes to the product described in this manual at any time and without notice. This product, including software and documentation, is the property of Supermicro and/or its licensors, and is supplied only under a license. Any use or reproduction of this product is not allowed, except as expressly permitted by the terms of said license.

IN NO EVENT WILL SUPERMICRO BE LIABLE FOR DIRECT, INDIRECT, SPECIAL, INCIDENTAL, SPECULATIVE OR CONSEQUENTIAL DAMAGES ARISING FROM THE USE OR INABILITY TO USE THIS PRODUCT OR DOCUMENTATION, EVEN IF ADVISED OF THE POSSIBILITY OF SUCH DAMAGES. IN PARTICULAR, SUPERMICRO SHALL NOT HAVE LIABILITY FOR ANY HARDWARE, SOFTWARE, OR DATA STORED OR USED WITH THE PRODUCT, INCLUDING THE COSTS OF REPAIRING, REPLACING, INTEGRATING, INSTALLING OR RECOVERING SUCH HARDWARE, SOFTWARE, OR DATA.

Any disputes arising between manufacturer and customer shall be governed by the laws of Santa Clara County in the State of California, USA. The State of California, County of Santa Clara shall be the exclusive venue for the resolution of any such disputes. Super Micro's total liability for all claims will not exceed the price paid for the hardware product.

FCC Statement: This equipment has been tested and found to comply with the limits for a Class A digital device pursuant to Part 15 of the FCC Rules. These limits are designed to provide reasonable protection against harmful interference when the equipment is operated in a commercial environment. This equipment generates, uses, and can radiate radio frequency energy and, if not installed and used in accordance with the manufacturer's instruction manual, may cause harmful interference with radio communications. Operation of this equipment in a residential area is likely to cause harmful interference, in which case you will be required to correct the interference at your own expense.

California Best Management Practices Regulations for Perchlorate Materials: This Perchlorate warning applies only to products containing CR (Manganese Dioxide) Lithium coin cells. "Perchlorate Material-special handling may apply. See [www.dtsc.ca.gov/hazardouswaste/perchlorate](http://www.dtsc.ca.gov/hazardouswaste/perchlorate)"

**WARNING: Handling of lead solder materials used in this product may expose you to lead, a chemical known to the State of California to cause birth defects and other reproductive harm.**

Manual Revision 1.0  
Release Date: August 14, 2013

Unless you request and receive written permission from Super Micro Computer, Inc., you may not copy any part of this document.

Information in this document is subject to change without notice. Other products and companies referred to herein are trademarks or registered trademarks of their respective companies or mark holders.

Copyright © 2013 by Super Micro Computer, Inc.  
All rights reserved.

**Printed in the United States of America**

# Preface

## About This Manual

This manual is written for professional system integrators and PC technicians. It provides information for the installation and use of the SuperServer 1027GR-72RT2+/72R2+/TRT2+/TR2+. Installation and maintenance should be performed by experienced technicians only.

The SuperServer 1027GR-72RT2+/72R2+/TRT2+/TR2+ is based on the SC-118GH-R1K66B 1U server chassis and the Super X9DRG-HF+II/X9DRG-HFT+II serverboard. Please refer to our web site for an up-to-date list of supported operating systems, processors and memory. See Chapter 1 for a list of differences between the server models.

## Manual Organization

### Chapter 1: Introduction

The first chapter provides a checklist of the main components included with the server system and describes the main features of the Super X9DRG-HF+II/X9DRG-HFT+II serverboard and the SC118GH-R1K66B chassis.

### Chapter 2: Server Installation

This chapter describes the steps necessary to install the system into a rack and check out the server configuration prior to powering up the system. If your server was ordered without the processor and memory components, this chapter will refer you to the appropriate sections of the manual for their installation.

### Chapter 3: System Interface

Refer to this chapter for details on the system interface, which includes the functions and information provided by the control panel on the chassis as well as other LEDs located throughout the system.

### Chapter 4: Standardized Safety Warnings

You should thoroughly familiarize yourself with this chapter for a general overview of safety precautions that should be followed when installing and servicing the system.

## **Chapter 5: Advanced Serverboard Setup**

Chapter 5 provides detailed information on the X9DRG-HF+II/X9DRG-HFT+II serverboard, including the locations and functions of connectors, headers and jumpers. Refer to this chapter when adding or removing processors or main memory and when reconfiguring the serverboard.

## **Chapter 6: Advanced Chassis Setup**

Refer to Chapter 6 for detailed information on the SC118GH-R1K66B 1U rackmount server chassis. You should follow the procedures given in this chapter when installing, removing or reconfiguring SATA or peripheral drives and when replacing system power supply units and cooling fans.

## **Chapter 7: BIOS**

The BIOS chapter includes an introduction to BIOS and provides detailed information on running the CMOS Setup Utility.

## **Appendix A: BIOS Error Beep Codes**

## **Appendix B: System Specifications**

## Notes

# Table of Contents

## **Chapter 1 Introduction**

1-1	Overview .....	1-1
1-2	Serverboard Features .....	1-2
	Processors .....	1-2
	Memory .....	1-2
	Serial ATA .....	1-2
	PCI Expansion Slots .....	1-2
	Onboard Controllers/Ports .....	1-2
	IPMI .....	1-2
1-3	Server Chassis Features .....	1-3
	System Power .....	1-3
	SATA Subsystem .....	1-3
	Front Control Panel .....	1-3
	Cooling System .....	1-3
1-4	GPU Subsystem .....	1-4
1-4	Contacting Supermicro .....	1-6

## **Chapter 2 Server Installation**

2-1	Overview .....	2-1
2-2	Unpacking the System .....	2-1
2-3	Preparing for Setup .....	2-1
	Choosing a Setup Location .....	2-1
2-4	Warnings and Precautions! .....	2-2
	Rack Precautions .....	2-2
	Server Precautions .....	2-2
	Rack Mounting Considerations .....	2-3
	Ambient Operating Temperature .....	2-3
	Reduced Airflow .....	2-3
	Mechanical Loading .....	2-3
	Circuit Overloading .....	2-3
	Reliable Ground .....	2-3
2-5	Installing the System into a Rack .....	2-4
	Identifying the Sections of the Rack Rails .....	2-4
	Installing the Inner Rail Extensions .....	2-5
	Assembling the Outer Rails .....	2-6
	Installing the Outer Rails onto the Rack .....	2-7
	Installing and Removing the Chassis From a Rack .....	2-8

---

Installing the Server into a Telco Rack .....	2-9
<b>Chapter 3 System Interface</b>	
3-1 Overview .....	3-1
3-2 Control Panel Buttons .....	3-1
3-3 Control Panel LEDs .....	3-2
3-4 Drive Carrier LEDs .....	3-3
<b>Chapter 4 Standardized Warning Statements for AC Systems</b>	
4-1 About Standardized Warning Statements .....	4-1
Warning Definition .....	4-1
Installation Instructions .....	4-4
Circuit Breaker .....	4-5
Power Disconnection Warning .....	4-6
Equipment Installation .....	4-8
Restricted Area .....	4-9
Battery Handling .....	4-10
Redundant Power Supplies .....	4-12
Backplane Voltage .....	4-13
Comply with Local and National Electrical Codes .....	4-14
Product Disposal .....	4-15
Hot Swap Fan Warning .....	4-16
Power Cable and AC Adapter .....	4-18
<b>Chapter 5 Advanced Serverboard Setup</b>	
5-1 Handling the Serverboard .....	5-1
Precautions .....	5-1
Unpacking .....	5-1
5-2 Connecting Cables .....	5-2
Connecting Data Cables .....	5-2
Connecting Power Cables .....	5-2
Connecting the Control Panel .....	5-2
5-3 I/O Ports .....	5-3
5-5 Installing the Processor and Heatsink .....	5-4
Installing an LGA 2011 Processor .....	5-4
Installing a CPU Heatsink .....	5-7
Memory Support .....	5-8
Processor/DIMM Population Configurations .....	5-9
5-6 Expansion Cards .....	5-10
5-7 Serverboard Details .....	5-11
X9DRG-HF+II/ X9DRG-HTF+II Quick Reference .....	5-12

---

5-8	Connector Definitions .....	5-14
5-9	Jumper Settings .....	5-20
5-10	Onboard Indicators.....	5-22
5-11	SATA Ports .....	5-23
5-12	Installing Software.....	5-24
	SuperDoctor III .....	5-25
5-13	Onboard Battery.....	5-27

**Chapter 6 Advanced Chassis Setup**

6-1	Static-Sensitive Devices.....	6-1
	Precautions .....	6-1
6-2	Control Panel .....	6-2
6-3	System Cooling.....	6-2
	System Fan Failure.....	6-3
	Installing the Air Shroud.....	6-4
	Installing Graphics (GPU) Cards.....	6-5
6-4	Drive Bay Installation/Removal .....	6-6
	Accessing the Drive Bays .....	6-6
	Hard Drive Installation.....	6-6
6-5	Power Supply .....	6-9

**Chapter 7 BIOS**

7-1	Introduction.....	7-1
	Starting BIOS Setup Utility.....	7-1
	How To Change the Configuration Data.....	7-2
	Starting the Setup Utility .....	7-2
7-2	Main Setup .....	7-2
7-3	Advanced Setup Configurations.....	7-4
7-4	Event Logs .....	7-24
7-5	IPMI.....	7-26
7-6	Boot.....	7-28
7-7	Security.....	7-29
7-8	Save & Exit .....	7-31

**Appendix A BIOS Error Beep Codes**

**Appendix B System Specifications**



---

# Chapter 1

## Introduction

### 1-1 Overview

The SuperServer 1027GR-72RT2+/72R2+/TRT2+/TR2+ series is a GPU-optimized server comprised of two main subsystems: the SC118GH-R1K66B 1U server chassis and the X9DRG-HF+II/X9DRG-HFT+II serverboard. Please refer to our web site for information on operating systems that have been certified for use with the system ([www.supermicro.com](http://www.supermicro.com)).

- Ten 4-cm counter-rotating fans (FAN-0141L4)
- One air shroud (MCP-310-11803-0N)
- Two passive CPU heatsinks (SNK-P0047PS:CPU1 and SNK-P0047PSC:CPU2)
- Riser Cards
  - One RSC-R1UG-EA16+II riser card
  - One RSC-R1UG-E16AR+II riser card
  - One RSC-R1UG-E16AB+II riser card with PCI-E x16 for right hand side
  - One RSC-R1UG-E16R+II riser card with PCI-E x16 for right hand side (TRT and TRT2+)
  - One AOC-S2208-E16AR+II-O-P
- Six power cables for GPU cards (CBL-0333L)
- SATA Accessories
  - One SAS backplane (BPN-SAS-118G-4)
  - Four hot-swap drive carriers (MCP-220-00047-0B)
  - Four SATA cables (CBL-0207L, CBL-0227L, 2 pcs. of CBL-0228L)
  - One SGPIO cable (CBL-0157L)
  - One backplane power ext. (CBL-0460L)
  - Five fan extension cables (CBL-0296L)
- One rail set (MCP-290-00054-0N)

**Note:** a complete list of safety warnings is provided on the Supermicro web site at [http://www.supermicro.com/about/policies/safety\\_information.cfm](http://www.supermicro.com/about/policies/safety_information.cfm)

## 1-2 Serverboard Features

At the heart of the SuperServer 1027GR-72RT2+/72R2+/TRT2+/TR2+ server is the X9DRG-HF+II/X9DRG-HFT+II , a dual processor serverboard based on the Intel C602 chipset. Below are the main features of the X9DRG-HF+II/X9DRG-HFT+II . (See Figure 1-1 for a block diagram of the chipset).

### Processors

The X9DRG-HF+II/X9DRG-HFT+II supports two Intel E5-2600 series processors in LGA 2011 sockets (Socket R). Please refer to the serverboard description pages on our web site for a complete listing of supported processors ([www.supermicro.com](http://www.supermicro.com)).

### Memory

The X9DRG-HF+II/X9DRG-HFT+II has 16 DIMM slots that can support up to 512 GB of registered ECC DDR3-1600/1333/1066 MHz RDIMMs or 128 GB of ECC/non-ECC UDIMMs. Modules of the same size and speed are recommended. See Chapter 5 for details.

### Serial ATA

The serverboard supports a 10-port SATA subsystem, which is RAID 0, 1, 5 and 10 supported. Two of these are SATA 3.0 ports and eight are SATA 2.0 ports. The SATA drives are hot-swappable units.

### PCI Expansion Slots

The X9DRG-HF+II/X9DRG-HFT+II has four PCI-Express 3.0 x16 slots to support three double-width GPU cards. Additional slots support one PCI-Express 3.0 x8 (in x16 slot) and one PCI-Express 2.0 x4 (in x8 slot). Note that both CPUs must be installed for full use of the PCI-E slots.

### Onboard Controllers/Ports

The rear I/O ports include a VGA (monitor) port, two USB 2.0 ports, two Gb Ethernet LAN ports (plus two 10 Gb ports on the X9DRG-HFT+II) and one dedicated IPMI LAN port.

### IPMI

IPMI (Intelligent Platform Management Interface) is a hardware-level interface specification that provides remote access, monitoring and administration for Supermicro

server platforms. IPMI allows server administrators to view a server's hardware status remotely, receive an alarm automatically if a failure occurs, and power cycle a system that is non-responsive.

## 1-3 Server Chassis Features

### System Power

The SC118GH-R1K66B features a high-efficiency 1600W redundant power supply. One power module may be removed without shutting down the system. See Chapter 6 for details.

### SATA Subsystem

The SC118GH-R1K66B chassis includes four 2.5" drive bays, which may be used to house hot-swappable SATA drives. RAID 0, 1, 5 and 10 are supported (RAID 5 is not supported with Linux OS).

### Front Control Panel

The control panel provides a system monitoring and control interface. LEDs indicate system power, HDD activity, network activity, system overheat, UID and power supply failure. A main power button and a system reset button are also included.

### Cooling System

The SC118GH-R1K66B has an innovative cooling design that includes ten 4-cm counter-rotating PWM (Pulse Width Modulated) fans. The power supply module also includes a cooling fan. All chassis and power supply fans operate continuously. These GPU servers include an air shroud (one for each GPU card) to further help cool the GPUs.

## 1-4 GPU Subsystem

The 1027GR-72RT2+/72R2+/TRT2+/TR2+ server represents one of Supermicro's massively parallel processing multiple-GPU servers, with support for up to three GPUs. NVIDIA® Fermi™ and Kepler™ GPUs place this system at the forefront of today's GPU computing solutions.

Please refer to the NVIDIA web site ([www.nvidia.com](http://www.nvidia.com)) for details on Fermi GPUs.

### Notes

The 1027GR-72RT2+/72R2+/TRT2+/TR2+ all support NVIDIA M2090 and M2075 GPUs and K10, K20 and K20X (Kepler) GPUs. All four server models also include SATA and 1 Gb Ethernet ports. The differences between the four models are as follows:

1027GR-72RT2+: includes SAS (with add-on card controller) and 10 Gb Ethernet/

1027GR-72R2+: includes SAS (with add-on card controller)

1027GR-TRT2+: includes 10 Gb Ethernet.

1027GR-TR2+: basic features (no SAS and no 10 Gb Ethernet).

Note: NVIDIA Kepler™ GPUs (requires their own mounting brackets for installation: p/n MCP-240-00117-0N)

**Figure 1-1. Intel C602 Chipset:  
System Block Diagram**

**Note:** This is a general block diagram. Please see Chapter 5 for details.

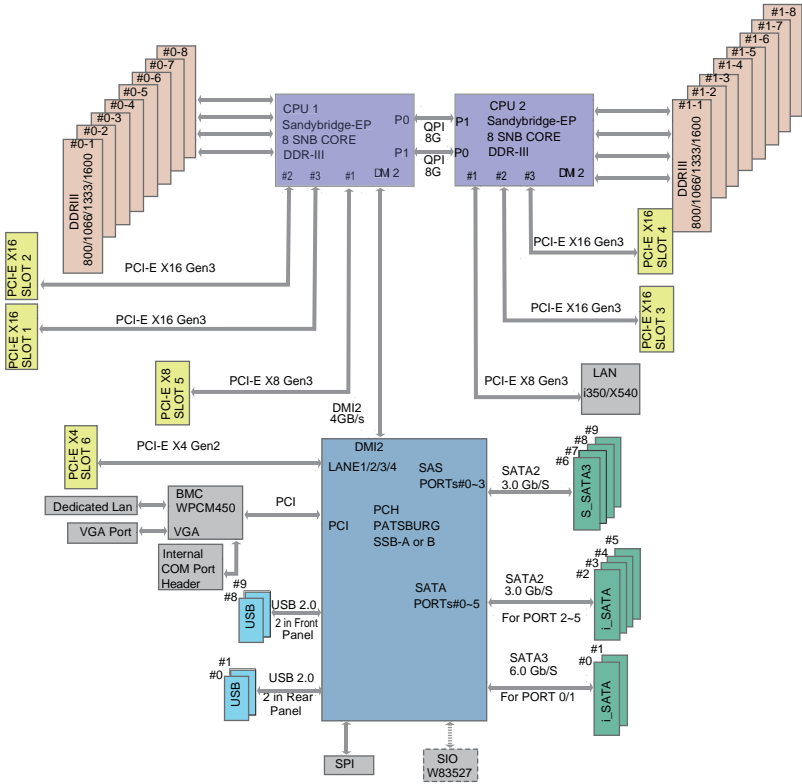

## 1-4 Contacting Supermicro

### Headquarters

Address: Super Micro Computer, Inc.  
980 Rock Ave.  
San Jose, CA 95131 U.S.A.

Tel: +1 (408) 503-8000

Fax: +1 (408) 503-8008

Email: [marketing@supermicro.com](mailto:marketing@supermicro.com) (General Information)  
[support@supermicro.com](mailto:support@supermicro.com) (Technical Support)

Web Site: [www.supermicro.com](http://www.supermicro.com)

### Europe

Address: Super Micro Computer B.V.  
Het Sterrenbeeld 28, 5215 ML  
's-Hertogenbosch, The Netherlands

Tel: +31 (0) 73-6400390

Fax: +31 (0) 73-6416525

Email: [sales@supermicro.nl](mailto:sales@supermicro.nl) (General Information)  
[support@supermicro.nl](mailto:support@supermicro.nl) (Technical Support)  
[rma@supermicro.nl](mailto:rma@supermicro.nl) (Customer Support)

### Asia-Pacific

Address: Super Micro Computer, Inc.  
3F, No. 150, Jian 1st Rd.  
Zhonghe Dist., New Taipei City 23511  
Taiwan (R.O.C)

Tel: +886-(2) 8226-3990

Fax: +886-(2) 8226-3992

Web Site: [www.supermicro.com.tw](http://www.supermicro.com.tw)

Technical Support:

Email: [support@supermicro.com.tw](mailto:support@supermicro.com.tw)

Tel: +886-(2)-8226-3990

## Chapter 2

# Server Installation

### 2-1 Overview

This chapter provides a quick setup checklist to get your system up and running. Following these steps in the order given should enable you to have the system operational within a minimum amount of time. This quick setup assumes that your system has come to you with the processors and memory preinstalled. If your system is not already fully integrated with a serverboard, processors, system memory etc., please turn to the chapter or section noted in each step for details on installing specific components.

### 2-2 Unpacking the System

You should inspect the box the system was shipped in and note if it was damaged in any way. If the server itself shows damage you should file a damage claim with the carrier who delivered it.

Decide on a suitable location for the rack unit that will hold the server. It should be situated in a clean, dust-free area that is well ventilated. Avoid areas where heat, electrical noise and electromagnetic fields are generated. You will also need it placed near a grounded power outlet. Read the Rack and Server Precautions in the next section.

### 2-3 Preparing for Setup

The box the server was shipped in should include two sets of rail assemblies, two rail mounting brackets and the mounting screws you will need to install the system into the rack. Follow the steps in the order given to complete the installation process in a minimum amount of time. Please read this section in its entirety before you begin the installation procedure outlined in the sections that follow.

#### Choosing a Setup Location

- Leave enough clearance in front of the rack to enable you to open the front door completely (~25 inches) and approximately 30 inches of clearance in the back of the rack to allow for sufficient airflow and ease in servicing. This product is for installation only in a Restricted Access Location (dedicated equipment rooms, service closets and the like).

- This product is not suitable for use with visual display work place devices according to §2 of the the German Ordinance for Work with Visual Display Units.

## 2-4 Warnings and Precautions!

### Rack Precautions

- Ensure that the leveling jacks on the bottom of the rack are fully extended to the floor with the full weight of the rack resting on them.
- In single rack installation, stabilizers should be attached to the rack. In multiple rack installations, the racks should be coupled together.
- Always make sure the rack is stable before extending a component from the rack.
- You should extend only one component at a time - extending two or more simultaneously may cause the rack to become unstable.
- Rack-mounted equipment should not be used as a shelf or work space.

### Server Precautions

- Review the electrical and general safety precautions in Chapter 4.
- Determine the placement of each component in the rack *before* you install the rails.
- Install the heaviest server components on the bottom of the rack first, and then work up.
- Use a regulating uninterruptible power supply (UPS) to protect the server from power surges, voltage spikes and to keep your system operating in case of a power failure.
- Allow the hot plug SATA drives and power supply modules to cool before touching them.
- Always keep the rack's front door and all panels and components on the servers closed when not servicing to maintain proper cooling.



## Rack Mounting Considerations

### ***Ambient Operating Temperature***

If installed in a closed or multi-unit rack assembly, the ambient operating temperature of the rack environment may be greater than the ambient temperature of the room. Therefore, consideration should be given to installing the equipment in an environment compatible with the manufacturer's maximum rated ambient temperature (T<sub>mra</sub>).

### ***Reduced Airflow***

Equipment should be mounted into a rack so that the amount of airflow required for safe operation is not compromised.

### ***Mechanical Loading***

Equipment should be mounted into a rack so that a hazardous condition does not arise due to uneven mechanical loading.

### ***Circuit Overloading***

Consideration should be given to the connection of the equipment to the power supply circuitry and the effect that any possible overloading of circuits might have on overcurrent protection and power supply wiring. Appropriate consideration of equipment nameplate ratings should be used when addressing this concern.

### ***Reliable Ground***

A reliable ground must be maintained at all times. To ensure this, the rack itself should be grounded. Particular attention should be given to power supply connections other than the direct connections to the branch circuit (i.e. the use of power strips, etc.).



**Warning!** To prevent bodily injury when mounting or servicing this unit in a rack, you must take special precautions to ensure that the system remains stable. The following guidelines are provided to ensure your safety:

- This unit should be mounted at the bottom of the rack if it is the only unit in the rack.
- When mounting this unit in a partially filled rack, load the rack from the bottom to the top with the heaviest component at the bottom of the rack.
- If the rack is provided with stabilizing devices, install the stabilizers before mounting or servicing the unit in the rack.

## 2-5 Installing the System into a Rack

This section provides information on installing the SC118GH chassis into a rack unit with the rails provided. There are a variety of rack units on the market, which may mean that the assembly procedure will differ slightly. You should also refer to the installation instructions that came with the rack unit you are using.

**Note:** This rail will fit a rack between 26" and 33.5" deep.



**Stability hazard.** The rack stabilizing mechanism must be in place, or the rack must be bolted to the floor before you slide the unit out for servicing. Failure to stabilize the rack can cause the rack to tip over.

### Identifying the Sections of the Rack Rails

The chassis package includes two rack rail assemblies in the rack mounting kit. Each assembly consists of two sections: an inner fixed chassis rail that secures directly to the server chassis and an outer fixed rack rail that secures directly to the rack itself.

Figure 2-1. Identifying the Sections of the Rack Rails

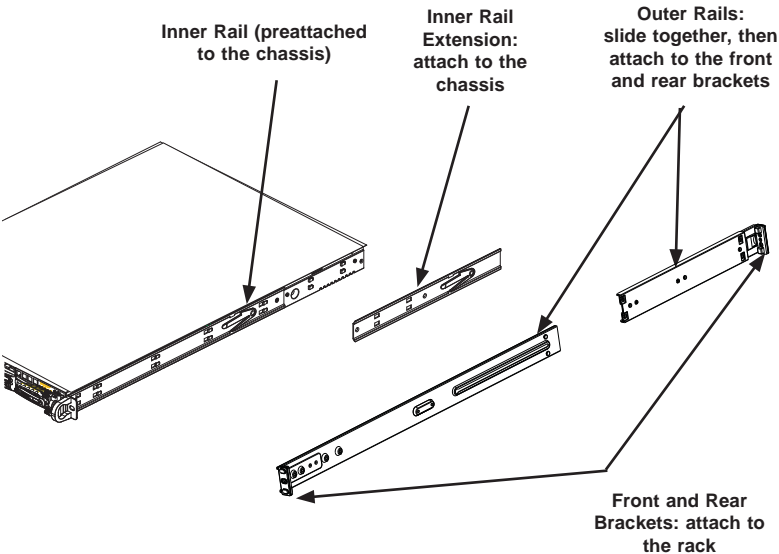

## Installing the Inner Rail Extensions

The SC118GH chassis includes a set of inner rack rails in two sections: inner rails (A) and inner rail extensions (B). The inner rails are preattached and do not interfere with normal use of the chassis if you decide not to install to a server rack. Attaching the inner rail extensions to the inner rails stabilizes the chassis within the rack.

### *Installing the Inner Rail Extensions*

1. Place the inner rail extensions (B) over the preattached inner rails (A) which are attached to the side of the chassis. Align the hooks of the inner rail with the rail extension holes. Make sure the extension faces "outward" just like the inner rail.
2. Slide the extension toward the front of the chassis.
3. Secure the chassis with screws as illustrated.
4. Repeat steps 1-3 for the other inner rail extension.

**Figure 2-2. Installing the Inner Rails**

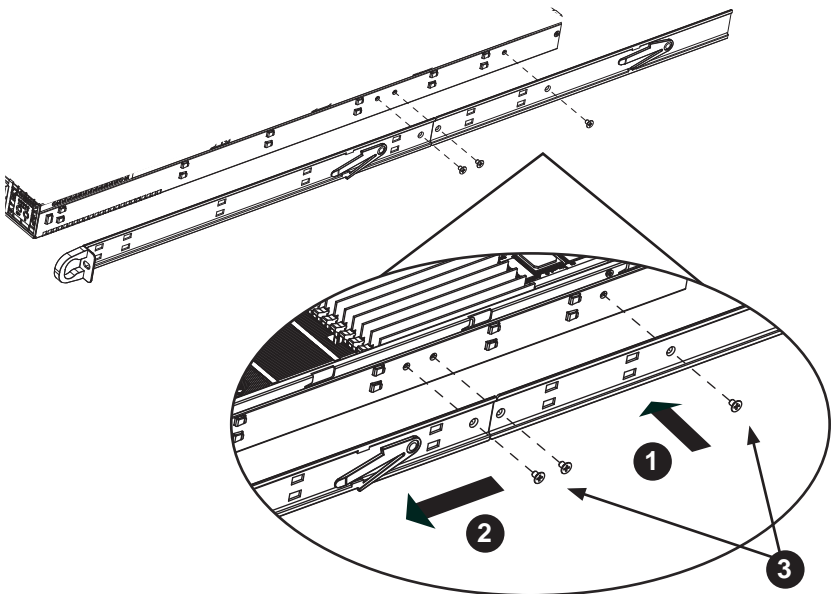

## Assembling the Outer Rails

Each outer rail is in two sections that must be assembled before mounting on to the rack.

### Assembling the Outer Rails

1. Identify the left and right outer rails by examining the ends, which bend outward.
2. Slide the front section of the outer rail (A), into the rear section of the outer rail (B).

Figure 2-3. Assembling the Outer Rails

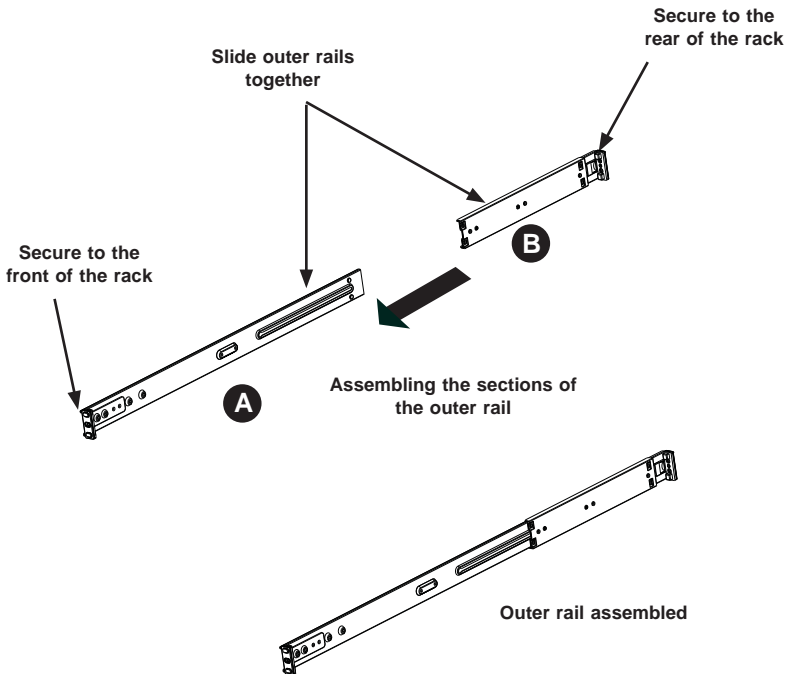

**Warning:** do not pick up the server with the front handles. They are designed to pull the system from a rack only.

## Installing the Outer Rails onto the Rack

### *Outer Rail Installation*

1. Adjust the outer rails to the proper length so that the outer rail fits snugly within the rack.
2. Align the holes on the front of the outer rail, with the holes on the front of the rack (C) and secure with the screws provided.
3. Align the holes on the rear of the outer rail to the holes on the rack (D) and secure with the screws provided.
4. Repeat the procedure with the second outer rail assembly.

**Figure 2-4. Installing the Outer Rails to the Rack**

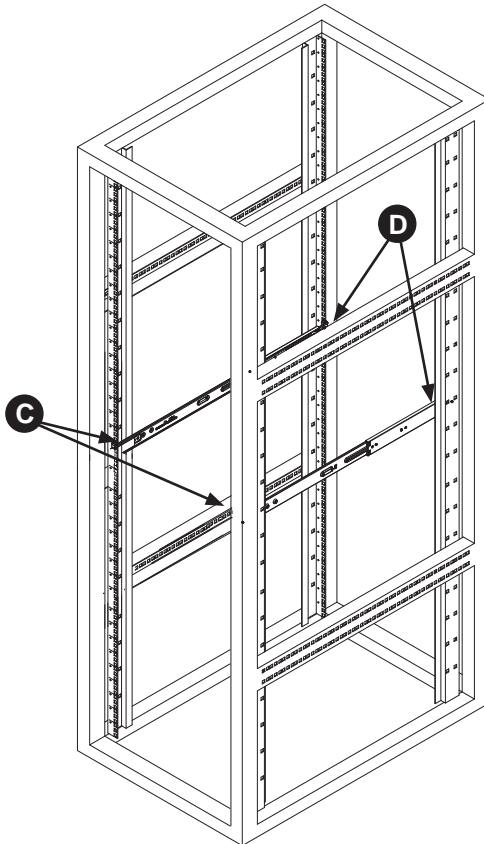

## Installing and Removing the Chassis From a Rack

### *Installation into a Rack*

1. Slide the inner rail extensions into the front of the outer rails.
2. Push the chassis backward into the rack until it clicks into the locked position.

### *Removing the Chassis From a Rack*

1. Press the outer rail latch to release the chassis.
2. Carefully slide the chassis forward, off the outer rails and out of the chassis.

Figure 2-5. Server Installation and Removal

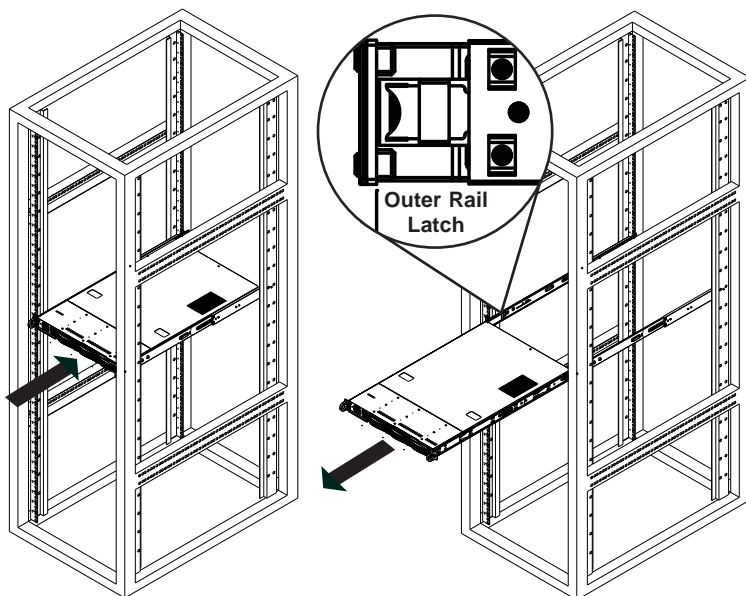

## Installing the Server into a Telco Rack

Optional brackets are needed to install the server to a telco (open type) rack.

To install the server into a Telco type rack, use the two L-shaped brackets on either side of the chassis (four total). First, determine how far follow the server will extend out the front of the rack. Larger chassis should be positioned to balance the weight between front and back. If a bezel is included on your server, remove it. Then attach the two front brackets to each side of the chassis, then the two rear brackets positioned with just enough space to accommodate the width of the telco rack. Finish by sliding the chassis into the rack and tightening the brackets to the rack.

**Figure 2-6. Installing the Server into a Telco Rack**

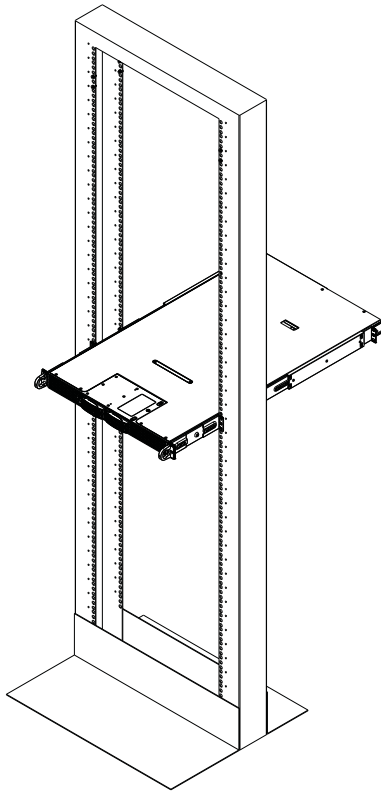

**Note:** Figures are for illustrative purposes only. Servers should always be installed into racks starting at the bottom.

## Notes



# Chapter 3

## System Interface

### 3-1 Overview

There are several LEDs on the control panel as well as others on the drive carriers to keep you constantly informed of the overall status of the system as well as the activity and health of specific components. There are also two buttons on the chassis control panel. This chapter explains the meanings of all LED indicators and the appropriate response you may need to take.

### 3-2 Control Panel Buttons

There are two push-buttons located on the front of the chassis: a reset button and a power on/off button.

RESET



**Reset**

Use the reset button to reboot the system.



**Power**

The main power button is used to apply or remove power from the power supply to the server system. Turning off system power with this button removes the main power but keeps standby power supplied to the system.

### 3-3 Control Panel LEDs

The two control panels are located on the front of the SC118GH chassis. Each control panel has six LEDs. These LEDs provide critical information related to different parts of the system. This section explains what each LED indicates when illuminated and any action that may be required..



#### Overheat/Fan Fail/UID LED

When this LED flashes it indicates a fan failure. When continuously on (not flashing) it indicates an overheat condition, which may be caused by cables obstructing the airflow in the system or the ambient room temperature being too warm. Check the routing of the cables and make sure that all fans are present and operating normally. Also check to make sure that the air shrouds are installed and that the top cover is on. Finally, verify that the heatsinks are installed properly.

This LED will remain flashing or on as long as the overheat condition exists. When used with a UID-compatible motherboard, the UID function is used to turn on or off the blue light function of the the LED. Once the blue light is activated through the system software, the unit can be easily located in very large racks and server banks.



#### NIC1

Indicates network activity on GLAN1 when flashing .



#### NIC2

Indicates network activity on GLAN2 when flashing .



## HDD

This light indicates SATA and/or peripheral drive activity when flashing.



## Power

Indicates power is being supplied to the system's power supply units. This LED should normally be illuminated when the system is operating.

### 3-4 Drive Carrier LEDs

- **Green:** Each hard drive carrier (for use with SATA drives) has a green LED. When illuminated, this green LED (on the front of the SATA drive carrier) indicates drive activity. A connection to the backplane enables this LED to blink on and off when that particular drive is being accessed. Please refer to Chapter 6 for instructions on replacing failed SATA drives.
- **Red:** The red LED to indicate a SATA drive failure. If one of the SATA drives fail, you should be notified by your system management software. Please refer to Chapter 6 for instructions on replacing failed SATA drives.

## Notes

## Chapter 4

# Standardized Warning Statements for AC Systems

### 4-1 About Standardized Warning Statements

The following statements are industry standard warnings, provided to warn the user of situations which have the potential for bodily injury. Should you have questions or experience difficulty, contact Supermicro's Technical Support department for assistance. Only certified technicians should attempt to install or configure components.

Read this appendix in its entirety before installing or configuring components in the Supermicro chassis.

These warnings may also be found on our web site at [http://www.supermicro.com/about/policies/safety\\_information.cfm](http://www.supermicro.com/about/policies/safety_information.cfm).

#### Warning Definition



#### Warning!

This warning symbol means danger. You are in a situation that could cause bodily injury. Before you work on any equipment, be aware of the hazards involved with electrical circuitry and be familiar with standard practices for preventing accidents.

#### 警告の定義

この警告サインは危険を意味します。

人身事故につながる可能性がありますので、いずれの機器でも動作させる前に、電気回路に含まれる危険性に注意して、標準的な事故防止策に精通して下さい。

此警告符号代表危險。

您正处于可能受到严重伤害的工作环境中。在您使用设备开始工作之前，必须充分意识到触电的危险，并熟练掌握防止事故发生的标准工作程序。请根据每项警告结尾的声明号码找到此设备的安全性警告说明的翻译文本。

此警告符號代表危險。

您正處於可能身體可能會受損傷的工作環境中。在您使用任何設備之前，請注意觸電的危險，並且要熟悉預防事故發生的標準工作程序。請依照每一注意事項後的號碼找到相關的翻譯說明內容。

## Warnung

### WICHTIGE SICHERHEITSHINWEISE

Dieses Warnsymbol bedeutet Gefahr. Sie befinden sich in einer Situation, die zu Verletzungen führen kann. Machen Sie sich vor der Arbeit mit Geräten mit den Gefahren elektrischer Schaltungen und den üblichen Verfahren zur Vorbeugung vor Unfällen vertraut. Suchen Sie mit der am Ende jeder Warnung angegebenen Anweisungsnummer nach der jeweiligen Übersetzung in den übersetzten Sicherheitshinweisen, die zusammen mit diesem Gerät ausgeliefert wurden.

BEWAHREN SIE DIESE HINWEISE GUT AUF.

### INSTRUCCIONES IMPORTANTES DE SEGURIDAD

Este símbolo de aviso indica peligro. Existe riesgo para su integridad física. Antes de manipular cualquier equipo, considere los riesgos de la corriente eléctrica y familiarícese con los procedimientos estándar de prevención de accidentes. Al final de cada advertencia encontrará el número que le ayudará a encontrar el texto traducido en el apartado de traducciones que acompaña a este dispositivo.

GUARDE ESTAS INSTRUCCIONES.

### IMPORTANTES INFORMATIONS DE SÉCURITÉ

Ce symbole d'avertissement indique un danger. Vous vous trouvez dans une situation pouvant entraîner des blessures ou des dommages corporels. Avant de travailler sur un équipement, soyez conscient des dangers liés aux circuits électriques et familiarisez-vous avec les procédures couramment utilisées pour éviter les accidents. Pour prendre connaissance des traductions des avertissements figurant dans les consignes de sécurité traduites qui accompagnent cet appareil, référez-vous au numéro de l'instruction situé à la fin de chaque avertissement.

CONSERVEZ CES INFORMATIONS.

## תקנת הצהרות אזהרה

הצהרות הבאות הן אזהרות על פי תקני התעשייה, על מנת להזהיר את המשתמש מפני חבלה פיזית אפשרית. במידה ויש שאלות או היתקלות בבעיה כלשהי, יש ליצור קשר עם מחלקת תמיכה טכנית של סופרמיקרו. טכנאים מוסמכים בלבד רשאים להתקין או להגדיר את הרכיבים.

יש לקרוא את הנספח במלואו לפני התקנת או הגדרת הרכיבים במארוי סופרמיקרו.

تحذير! هذا الرمز يعني خطر انك في حالة يمكن أن تتسبب في اصابة جسدية .  
قبل أن تعمل على أي معدات، كن على علم بالمخاطر الناجمة عن الدوائر  
الكهربائية  
وكن على دراية بالممارسات الوقائية لمنع وقوع أي حوادث  
استخدم رقم البيان المنصوص في نهاية كل تحذير للعثور ترجمتها

안전을 위한 주의사항

경고!

이 경고 기호는 위험이 있음을 알려 줍니다. 작업자의 신체에 부상을 야기 할 수 있는 상태에 있게 됩니다. 모든 장비에 대한 작업을 수행하기 전에 전기회로와 관련된 위험요소들을 확인하시고 사전에 사고를 방지할 수 있도록 표준 작업절차를 준수해 주시기 바랍니다.

해당 번역문을 찾기 위해 각 경고의 마지막 부분에 제공된 경고문 번호를 참조하십시오

#### BELANGRIJKE VEILIGHEIDSINSTRUCTIES

Dit waarschuwings symbool betekent gevaar. U verkeert in een situatie die lichamelijk letsel kan veroorzaken. Voordat u aan enige apparatuur gaat werken, dient u zich bewust te zijn van de bij een elektrische installatie betrokken risico's en dient u op de hoogte te zijn van de standaard procedures om ongelukken te voorkomen. Gebruik de nummers aan het eind van elke waarschuwing om deze te herleiden naar de desbetreffende locatie.

BEWAAR DEZE INSTRUCTIES

## Installation Instructions



### Warning!

Read the installation instructions before connecting the system to the power source.

設置手順書

システムを電源に接続する前に、設置手順書をお読み下さい。

警告

将此系统连接电源前，请先阅读安装说明。

警告

將系統與電源連接前，請先閱讀安裝說明。

Warnung

Vor dem Anschließen des Systems an die Stromquelle die Installationsanweisungen lesen.

¡Advertencia!

Lea las instrucciones de instalación antes de conectar el sistema a la red de alimentación.

Attention

Avant de brancher le système sur la source d'alimentation, consulter les directives d'installation.

יש לקרוא את הוראות התקנה לפני חיבור המערכת למקור מתח.

اقر إرشادات التركيب قبل توصيل النظام إلى مصدر للطاقة

시스템을 전원에 연결하기 전에 설치 안내를 읽어주시시오.

Waarschuwing

Raadpleeg de installatie-instructies voordat u het systeem op de voedingsbron aansluit.



## Circuit Breaker



### Warning!

This product relies on the building's installation for short-circuit (overcurrent) protection. Ensure that the protective device is rated not greater than: 250 V, 20 A.

サーキット・ブレーカー

この製品は、短絡(過電流)保護装置がある建物での設置を前提としています。

保護装置の定格が250 V、20 Aを超えないことを確認下さい。

### 警告

此产品的短路(过载电流)保护由建筑物的供电系统提供,确保短路保护设备的额定电流不大于250V,20A。

### 警告

此产品的短路(过载电流)保护由建筑物的供电系统提供,确保短路保护设备的额定电流不大于250V,20A。

### Warnung

Dieses Produkt ist darauf angewiesen, dass im Gebäude ein Kurzschluss- bzw. Überstromschutz installiert ist. Stellen Sie sicher, dass der Nennwert der Schutzvorrichtung nicht mehr als: 250 V, 20 A beträgt.

### ¡Advertencia!

Este equipo utiliza el sistema de protección contra cortocircuitos (o sobrecorrientes) del edificio. Asegúrese de que el dispositivo de protección no sea superior a: 250 V, 20 A.

### Attention

Pour ce qui est de la protection contre les courts-circuits (surtension), ce produit dépend de l'installation électrique du local. Vérifiez que le courant nominal du dispositif de protection n'est pas supérieur à :250 V, 20 A.

מוצר זה מסתמך על הגנה המותקנת במבנים למניעת קצר חשמלי. יש לוודא  
המכשיר המגן מפני הקצר החשמלי הוא לא יותר מ-20A, 60VDC

هذا المنتج يعتمد على معدات الحماية من الدوائر القصيرة التي تم تثبيتها في  
المبنى

تأكد من أن تقيّم الجهاز الوقائي ليس أكثر من: 20A, 250VDC

경고!

이 제품은 전원의 단락(과전류)방지에 대해서 전적으로 건물의 관련 설비에 의존합니다. 보호장치의 정격이 반드시 250V(볼트), 20A(암페어)를 초과하지 않도록 해야 합니다.

Waarschuwing

Dit product is afhankelijk van de kortsluitbeveiliging (overspanning) van uw elektrische installatie. Controleer of het beveiligde apparaat niet groter gedimensioneerd is dan 220V, 20A.

## Power Disconnection Warning



### Warning!

The system must be disconnected from all sources of power and the power cord removed from the power supply module(s) before accessing the chassis interior to install or remove system components.

### 電源切斷の警告

システムコンポーネントの取り付けまたは取り外しのために、シャーシ内部にアクセスするには、

システムの電源はすべてのソースから切斷され、電源コードは電源モジュールから取り外す必要があります。

警告

在你打开机箱并安装或移除内部器件前，必须将系统完全断电，并移除电源线。

警告

在您打開機殼安裝或移除內部元件前，必須將系統完全斷電，並移除電源線。

Warnung

Das System muss von allen Quellen der Energie und vom Netzanschlusskabel getrennt sein, das von den Spg.Versorgungsteilmodulen entfernt wird, bevor es auf den Chassisinnenraum zurückgreift, um Systemsbestandteile anzubringen oder zu entfernen.

¡Advertencia!

El sistema debe ser disconnected de todas las fuentes de energía y del cable eléctrico quitado de los módulos de fuente de alimentación antes de tener acceso el interior del chasis para instalar o para quitar componentes de sistema.

Attention

Le système doit être débranché de toutes les sources de puissance ainsi que de son cordon d'alimentation secteur avant d'accéder à l'intérieur du châssis pour installer ou enlever des composants de système.

**אזהרה!**

יש לנתק את המערכת מכל מקורות החשמל ויש להסיר את כבל החשמלי מהספק לפני גישה לחלק הפנימי של המארז לצורך התקנת או הסרת רכיבים.

يجب فصل النظام من جميع مصادر الطاقة وإزالة سلك الكهرباء من وحدة امداد الطاقة قبل الوصول إلى المناطق الداخلية للهيكल لتثبيت أو إزالة مكونات الجهاز

경고!

시스템에 부품들을 장착하거나 제거하기 위해서는 새시 내부에 접근하기 전에 반드시 전원 공급장치로부터 연결되어있는 모든 전원과 전기코드를 분리해주어야 합니다.

Waarschuwing

Voordat u toegang neemt tot het binnenwerk van de behuizing voor het installeren of verwijderen van systeem onderdelen, dient u alle spanningsbronnen en alle stroomkabels aangesloten op de voeding(en) van de behuizing te verwijderen

## Equipment Installation



### Warning!

Only trained and qualified personnel should be allowed to install, replace, or service this equipment.

### 機器の設置

トレーニングを受け認定された人だけがこの装置の設置、交換、またはサービスを許可されています。

### 警告

只有经过培训且具有资格的人员才能进行此设备的安装、更换和维修。

### 警告

只有經過受訓且具資格人員才可安裝、更換與維修此設備。

### Warnung

Das Installieren, Ersetzen oder Bedienen dieser Ausrüstung sollte nur geschultem, qualifiziertem Personal gestattet werden.

### ¡Advertencia!

Solamente el personal calificado debe instalar, reemplazar o utilizar este equipo.

### Attention

Il est vivement recommandé de confier l'installation, le remplacement et la maintenance de ces équipements à des personnels qualifiés et expérimentés.

### אזהרה!

צוות מוסמך בלבד רשאי להתקין, להחליף את הציוד או לתת שירות עבור הציוד.

يجب أن يسمح فقط للموظفين المؤهلين والمدربين لتثبيت واستبدال أو خدمة هذا الجهاز

### 경고!

훈련을 받고 공인된 기술자만이 이 장비의 설치, 교체 또는 서비스를 수행할 수 있습니다.

## Waarschuwing

Deze apparatuur mag alleen worden geïnstalleerd, vervangen of hersteld door geschoold en gekwalificeerd personeel.

## Restricted Area



### Warning!

This unit is intended for installation in restricted access areas. A restricted access area can be accessed only through the use of a special tool, lock and key, or other means of security. (This warning does not apply to workstations).

## アクセス制限区域

このユニットは、アクセス制限区域に設置されることを想定しています。

アクセス制限区域は、特別なツール、鍵と錠前、その他のセキュリティの手段を用いてのみ出入りが可能です。

## 警告

此部件应安装在限制进出的场所，限制进出的场所指只能通过使用特殊工具、锁和钥匙或其它安全手段进出的场所。

## 警告

此裝置僅限安裝於進出管制區域，進出管制區域係指僅能以特殊工具、鎖頭及鑰匙或其他安全方式才能進入的區域。

## Warnung

Diese Einheit ist zur Installation in Bereichen mit beschränktem Zutritt vorgesehen. Der Zutritt zu derartigen Bereichen ist nur mit einem Spezialwerkzeug, Schloss und Schlüssel oder einer sonstigen Sicherheitsvorkehrung möglich.

## ¡Advertencia!

Esta unidad ha sido diseñada para instalación en áreas de acceso restringido. Sólo puede obtenerse acceso a una de estas áreas mediante la utilización de una herramienta especial, cerradura con llave u otro medio de seguridad.

## Attention

Cet appareil doit être installée dans des zones d'accès réservés. L'accès à une zone d'accès réservé n'est possible qu'en utilisant un outil spécial, un mécanisme de verrouillage et une clé, ou tout autre moyen de sécurité.

## אזור עם גישה מוגבלת

### אזהרה!

יש להתקין את היחידה באזורים שיש בהם הגבלת גישה. הגישה ניתנת בעזרת כלי אבטחה בלבד (מפתח, מנעול וכד').

تم تخصيص هذه الوحدة لت تركيبها في مناطق محظورة .  
يمكن الوصول إلى منطقة محظورة فقط من خلال استخدام أداة خاصة،  
قفل ومفتاح أو أي وسيلة أخرى للأمان

경고!

이 장치는 접근이 제한된 구역에 설치하도록 되어 있습니다. 특수도구, 잠금 장치 및 키, 또는 기타 보안 수단을 통해서만 접근 제한 구역에 들어갈 수 있습니다.

Waarschuwing

Dit apparaat is bedoeld voor installatie in gebieden met een beperkte toegang. Toegang tot dergelijke gebieden kunnen alleen verkregen worden door gebruik te maken van speciaal gereedschap, slot en sleutel of andere veiligheidsmaatregelen.

## Battery Handling



### Warning!

There is the danger of explosion if the battery is replaced incorrectly. Replace the battery only with the same or equivalent type recommended by the manufacturer. Dispose of used batteries according to the manufacturer's instructions

電池の取り扱い

電池交換が正しく行われなかった場合、破裂の危険性があります。交換する電池はメーカーが推奨する型、または同等のものを使用下さい。使用済電池は製造元の指示に従って処分して下さい。

警告

電池更換不當會有爆炸危險。請只使用同類電池或製造商推薦的功能相當的電池更換原有電池。請按製造商的說明處理廢舊電池。

警告

電池更換不當會有爆炸危險。請使用製造商建議之相同或功能相當的電池更換原有電池。請按照製造商的說明指示處理廢棄舊電池。

Warnung

Bei Einsetzen einer falschen Batterie besteht Explosionsgefahr. Ersetzen Sie die Batterie nur durch den gleichen oder vom Hersteller empfohlenen Batterietyp. Entsorgen Sie die benutzten Batterien nach den Anweisungen des Herstellers.

Attention

Danger d'explosion si la pile n'est pas remplacée correctement. Ne la remplacer que par une pile de type semblable ou équivalent, recommandée par le fabricant. Jeter les piles usagées conformément aux instructions du fabricant.

¡Advertencia!

Existe peligro de explosión si la batería se reemplaza de manera incorrecta. Reemplazar la batería exclusivamente con el mismo tipo o el equivalente recomendado por el fabricante. Desechar las baterías gastadas según las instrucciones del fabricante.

**אזהרה!**

קיימת סכנת פיצוץ של הסוללה במידה והוחלפה בדרך לא תקינה. יש להחליף את הסוללה בסוג התואם מחברת יצרן מומלצת.

סילוק הסוללות המשומשות יש לבצע לפי הוראות היצרן.

هناك خطر من انفجار في حالة استبدال البطارية بطريقة غير صحيحة فعليك استبدال البطارية فقط بنفس النوع أو ما يعادلها كما أوصت به الشركة المصنعة تخلص من البطاريات المستعملة وفقا لتعليمات الشركة الصانعة

경고!

배터리가 올바르게 교체되지 않으면 폭발의 위험이 있습니다. 기존 배터리와 동일하거나 제조사에서 권장하는 동등한 종류의 배터리로만 교체해야 합니다. 제조사의 안내에 따라 사용된 배터리를 처리하여 주십시오.

Waarschuwing

Er is ontploffingsgevaar indien de batterij verkeerd vervangen wordt. Vervang de batterij slechts met hetzelfde of een equivalent type die door de fabrikant aanbevolen wordt. Gebruikte batterijen dienen overeenkomstig fabrieksvoorschriften afgevoerd te worden.

## Redundant Power Supplies



### Warning!

This unit might have more than one power supply connection. All connections must be removed to de-energize the unit.

### 冗長電源装置

このユニットは複数の電源装置が接続されている場合があります。  
ユニットの電源を切るためには、すべての接続を取り外さなければなりません。

### 警告

此部件连接的电源可能不止一个，必须将所有电源断开才能停止给该部件供电。

### 警告

此装置连接的电源可能不只一个，必须切断所有电源才能停止对该装置的供电。

### Warnung

Dieses Gerät kann mehr als eine Stromzufuhr haben. Um sicherzustellen, dass der Einheit kein Strom zugeführt wird, müssen alle Verbindungen entfernt werden.

### ¡Advertencia!

Puede que esta unidad tenga más de una conexión para fuentes de alimentación. Para cortar por completo el suministro de energía, deben desconectarse todas las conexiones.

### Attention

Cette unité peut avoir plus d'une connexion d'alimentation. Pour supprimer toute tension et tout courant électrique de l'unité, toutes les connexions d'alimentation doivent être débranchées.

**אם קיים יותר מספק אחד**

**אזהרה!**

ליחידה יש יותר מחיבור אחד של ספק. יש להסיר את כל החיבורים על מנת לרוקן את היחידה.



قد يكون لهذا الجهاز عدة اتصالات بوحدات امداد الطاقة.  
يجب إزالة كافة الاتصالات لعزل الوحدة عن الكهرباء

경고!

이 장치에는 한 개 이상의 전원 공급 단자가 연결되어 있을 수 있습니다. 이 장치에 전원을 차단하기 위해서는 모든 연결 단자를 제거해야만 합니다.

Waarschuwing

Deze eenheid kan meer dan één stroomtoevoeraansluiting bevatten. Alle aansluitingen dienen verwijderd te worden om het apparaat stroomloos te maken.

### Backplane Voltage



**Warning!**

Hazardous voltage or energy is present on the backplane when the system is operating. Use caution when servicing.

バックプレーンの電圧

システムの稼働中は危険な電圧または電力が、バックプレーン上にかかっています。

修理する際にはご注意ください。

警告

当系統正在进行时，背板上有很危险的电压或能量，进行维修时务必小心。

警告

當系統正在進行時，背板上有危險的電壓或能量，進行維修時務必小心。

Warnung

Wenn das System in Betrieb ist, treten auf der Rückwandplatine gefährliche Spannungen oder Energien auf. Vorsicht bei der Wartung.

¡Advertencia!

Cuando el sistema está en funcionamiento, el voltaje del plano trasero es peligroso. Tenga cuidado cuando lo revise.

Attention

Lorsque le système est en fonctionnement, des tensions électriques circulent sur le fond de panier. Prendre des précautions lors de la maintenance.

## מתח בפנל האחורי

אזהרה!  
קיימת סכנת מתח בפנל האחורי בזמן תפעול המערכת. יש להיזהר במהלך  
העבודה.

هناك خطر من التيار الكهربائي أو الطاقة الموجودة على اللوحة  
عندما يكون النظام يعمل كن حذرا عند خدمة هذا الجهاز

경고!

시스템이 동작 중일 때 후면판 (Backplane)에는 위험한 전압이나 에너지가 발생  
합니다. 서비스 작업 시 주의하십시오.

Waarschuwing

Een gevaarlijke spanning of energie is aanwezig op de backplane wanneer het  
systeem in gebruik is. Voorzichtigheid is geboden tijdens het onderhoud.

## Comply with Local and National Electrical Codes



### Warning!

Installation of the equipment must comply with local and national electrical codes.

地方および国の電気規格に準拠

機器の取り付けはその地方および国の電気規格に準拠する必要があります。

警告

设备安装必须符合本地与本国电气法规。

警告

設備安裝必須符合本地與本國電氣法規。

Warnung

Die Installation der Geräte muss den Sicherheitsstandards entsprechen.

¡Advertencia!

La instalación del equipo debe cumplir con las normas de electricidad locales y  
nacionales.

Attention

L'équipement doit être installé conformément aux normes électriques nationales et locales.

**תיאום חוקי החשמל הארצי**

**אזהרה!**

התקנת הציוד חייבת להיות תואמת לחוקי החשמל המקומיים והארציים.

تركيب المعدات الكهربائية يجب أن يمتثل للقوانين المحلية والوطنية المتعلقة بالكهرباء

경고!

현 지역 및 국가의 전기 규정에 따라 장비를 설치해야 합니다.

Waarschuwing

Bij installatie van de apparatuur moet worden voldaan aan de lokale en nationale elektriciteitsvoorschriften.

**Product Disposal**



**Warning!**

Ultimate disposal of this product should be handled according to all national laws and regulations.

**製品の廃棄**

この製品を廃棄処分する場合、国の関係する全ての法律・条例に従い処理する必要があります。

**警告**

本产品的废弃处理应根据所有国家的法律和规章进行。

**警告**

本產品的廢棄處理應根據所有國家的法律和規章進行。

Warnung

Die Entsorgung dieses Produkts sollte gemäß allen Bestimmungen und Gesetzen des Landes erfolgen.

¡Advertencia!

Al deshacerse por completo de este producto debe seguir todas las leyes y reglamentos nacionales.

Attention

La mise au rebut ou le recyclage de ce produit sont généralement soumis à des lois et/ou directives de respect de l'environnement. Renseignez-vous auprès de l'organisme compétent.

## סילוק המוצר

אזהרה!

סילוק סופי של מוצר זה חייב להיות בהתאם להנחיות וחוקי המדינה.

عند التخلص النهائي من هذا المنتج ينبغي التعامل معه وفقا لجميع القوانين واللوائح الوطنية

경고!

이 제품은 해당 국가의 관련 법규 및 규정에 따라 폐기되어야 합니다.

Waarschuwing

De uiteindelijke verwijdering van dit product dient te geschieden in overeenstemming met alle nationale wetten en reglementen.

## Hot Swap Fan Warning



### Warning!

The fans might still be turning when you remove the fan assembly from the chassis. Keep fingers, screwdrivers, and other objects away from the openings in the fan assembly's housing.

ファン・ホットスワップの警告

シャーシから冷却ファン装置を取り外した際、ファンがまだ回転している可能性があります。ファンの開口部に、指、ドライバー、およびその他のものを近づけないで下さい。

警告

当您从机架移除风扇装置，风扇可能仍在转动。小心不要将手指、螺丝起子和其他物品太靠近风扇

**警告**

當您從機架移除風扇裝置，風扇可能仍在轉動。小心不要將手指、螺絲起子和其他物品太靠近風扇。

**Warnung**

Die Lüfter drehen sich u. U. noch, wenn die Lüfterbaugruppe aus dem Chassis genommen wird. Halten Sie Finger, Schraubendreher und andere Gegenstände von den Öffnungen des Lüftergehäuses entfernt.

**¡Advertencia!**

Los ventiladores podran dar vuelta cuando usted quite el montaje del ventilador del chasis. Mantenga los dedos, los destornilladores y todos los objetos lejos de las aberturas del ventilador

**Attention**

Il est possible que les ventilateurs soient toujours en rotation lorsque vous retirez le bloc ventilateur du châssis. Prenez garde à ce que doigts, tournevis et autres objets soient éloignés du logement du bloc ventilateur.

**אזהרה!**

כאשר מסירים את חלקי המאוורר מהמארז, יתכן והמאווררים עדיין עובדים. יש להרחיק למרחק בטוח את האצבעות וכלי עבודה שונים מהפתחים בתוך המאוורר

من الممكن أن المراوح لا تزال تدور عند إزالة كتلة المروحة من الهيكل يجب إبقاء الأصابع ومفكات البراغي وغيرها من الأشياء بعيدا عن الفتحات في كتلة المروحة.

**경고!**

새시로부터 팬 조립품을 제거할 때 팬은 여전히 회전하고 있을 수 있습니다. 팬 조립품 외관의 열려있는 부분들로부터 손가락 및 스크류드라이버, 다른 물체들이 가까이 하지 않도록 배치해 주십시오.

**Waarschuwing**

Het is mogelijk dat de ventilator nog draait tijdens het verwijderen van het ventilatorsamenstel uit het chassis. Houd uw vingers, schroevendraaiers en eventuele andere voorwerpen uit de buurt van de openingen in de ventilatorbehuizing.

## Power Cable and AC Adapter



### Warning!

When installing the product, use the provided or designated connection cables, power cables and AC adaptors. Using any other cables and adaptors could cause a malfunction or a fire. Electrical Appliance and Material Safety Law prohibits the use of UL or CSA -certified cables (that have UL/CSA shown on the code) for any other electrical devices than products designated by Supermicro only.

### 電源コードとACアダプター

製品を設置する場合、提供または指定された接続ケーブル、電源コードとACアダプターを使用下さい。他のケーブルやアダプタを使用すると故障や火災の原因になることがあります。電気用品安全法は、ULまたはCSA認定のケーブル(UL/CSEマークがコードに表記)をSupermicroが指定する製品以外に使用することを禁止しています。

### 警告

安裝此產品時，請使用本身提供的或指定的連接線，電源線和電源適配器。使用其它線材或適配器可能會引起故障或火災。除了Supermicro所指定的產品，電氣用品和材料安全法律規定禁止使用未經UL或CSA認證的線材。(線材上會顯示UL/CSA符號)。

### 警告

安裝此產品時，請使用本身提供的或指定的連接線，電源線和電源適配器。使用其它線材或適配器可能會引起故障或火災。除了Supermicro所指定的產品，電氣用品和材料安全法律規定禁止使用未經UL或CSA認證的線材。(線材上會顯示UL/CSA符號)。

### Warnung

Bei der Installation des Produkts, die zur Verfügung gestellten oder benannt Anschlusskabel, Stromkabel und Netzteile. Verwendung anderer Kabel und Adapter kann zu einer Fehlfunktion oder ein Brand entstehen. Elektrische Geräte und Material Safety Law verbietet die Verwendung von UL-oder CSA-zertifizierte Kabel, UL oder CSA auf der Code für alle anderen elektrischen Geräte als Produkte von Supermicro nur bezeichnet gezeigt haben.

### ¡Advertencia!

Al instalar el producto, utilice los cables de conexión previstos o designados, los cables y adaptadores de CA. La utilización de otros cables y adaptadores podría ocasionar un mal funcionamiento o un incendio. Aparatos Eléctricos y la Ley de Seguridad del Material prohíbe el uso de UL o CSA cables certificados que tienen UL o CSA se muestra en el código de otros dispositivos eléctricos que los productos designados por Supermicro solamente.

## Attention

Lors de l'installation du produit, utilisez les bables de connection fournis ou désigné. L'utilisation d'autres cables et adaptateurs peut provoquer un dysfonctionnement ou un incendie. Appareils électroménagers et de loi sur la sécurité Matériel interdit l'utilisation de UL ou CSA câbles certifiés qui ont UL ou CSA indiqué sur le code pour tous les autres appareils électriques que les produits désignés par Supermicro seulement.

## חשמליים ומתאמי AC

## אזהרה!

כאשר מתקינים את המוצר, יש להשתמש בכבלים, ספקים ומתאמים AC אשר נועדו וסופקו לשם כך. שימוש בכל כבל או מתאם אחר יכול לגרום לתקלה או קצר חשמלי. על פי חוקי שימוש במכשירי חשמל וחוקי בטיחות, קיים איסור להשתמש בכבלים המוסמכים ב- UL או ב- CSA (כשאר מופיע עליהם קוד של UL/CSA) עבור כל מוצר חשמלי אחר שלא צויין על ידי סופרמיקרו בלבד.

عند تركيب الجهاز يجب استخدام كابلات التوصيل، والكابلات الكهربائية ومحولات التيار المتردد التي . أن استخدام أي كابلات ومحولات أخرى يتسبب في حدوث عطل أو حريق. تم توفيرها لك مع المنتج الأجهزة الكهربائية ومواد قانون السلامة يحظر استخدام الكابلات CSA أو UL معتمدة من قبل لأي أجهزة كهربائية أخرى غير المنتجات المعينة من قبل Supermicro (التي تحمل علامة UL/CSA)

## 경고!

제품을 설치할 때에는 제공되거나 지정된 연결케이블과 전원케이블, AC 어댑터를 사용해야 합니다. 그 밖의 다른 케이블들이나 어댑터들은 고장 또는 화재의 원인이 될 수 있습니다. 전기용품안전법 (Electrical Appliance and Material Safety Law)은 슈퍼마이크로에서 지정한 제품들 외에는 그 밖의 다른 전기 장치들을 위한 UL 또는 CSA에서 인증한 케이블(전선 위에 UL/CSA가 표시)들의 사용을 금지합니다.

## Waarschuwing

Bij het installeren van het product, gebruik de meegeleverde of aangewezen kabels, stroomkabels en adapters. Het gebruik van andere kabels en adapters kan leiden tot een storing of een brand. Elektrisch apparaat en veiligheidsinformatiebladen wet verbiedt het gebruik van UL of CSA gecertificeerde kabels die UL of CSA die op de code voor andere elektrische apparaten dan de producten die door Supermicro alleen.

## Notes



## Chapter 5

# Advanced Serverboard Setup

This chapter covers the steps required to connect cables and install add-on cards and describes all jumpers and connections. A layout and quick reference chart are included in this chapter for your reference. Always close the chassis when you have finished working on the system to maintain optimal cooling.

### 5-1 Handling the Serverboard

Electrostatic Discharge (ESD) can damage electronic components. To prevent damage to any printed circuit boards (PCBs), it is important to handle them very carefully (see previous chapter). To prevent the serverboard from bending, keep one hand under the center of the board to support it when handling. The following measures are generally sufficient to protect your equipment from electric static discharge.

#### Precautions

- Use a grounded wrist strap designed to prevent Electrostatic Discharge (ESD).
- Touch a grounded metal object before removing any board from its antistatic bag.
- Handle a board by its edges only; do not touch its components, peripheral chips, memory modules or gold contacts.
- When handling chips or modules, avoid touching their pins.
- Put the serverboard, add-on cards and peripherals back into their antistatic bags when not in use.
- For grounding purposes, make sure your computer chassis provides excellent conductivity between the power supply, the case, the mounting fasteners and the serverboard.

#### Unpacking

The serverboard is shipped in antistatic packaging to avoid electrical static discharge. When unpacking the board, make sure the person handling it is static protected.

---

## 5-2 Connecting Cables

Now that the serverboard is installed, the next step is to connect the cables to the board. These include the data (ribbon) cables for the peripherals and control panel and the power cables.

### Connecting Data Cables

The ribbon cables used to transfer data from the peripheral devices have been carefully routed to prevent them from blocking the flow of cooling air that moves through the system from front to back. If you need to disconnect any of these cables, you should take care to keep them routed as they were originally after reconnecting them (make sure the red wires connect to the pin 1 locations). The following data cables (with their locations noted) should be connected. (See the layout on page 5-12 for connector locations.)

- SATA drive data cables (I-SATA0 ~ 3)
- SATA sideband cable (T-SGPIO ~ 1)
- Control Panel cable (JF1)
- GPU power cables (JPW3, JPW7 and JPW11)
- SATA backplane power cable (JPW5)

**Important!** Make sure the the cables do not come into contact with the fans.

### Connecting Power Cables

The X9DRG-HF+II/X9DRG-HFT+II has three proprietary power supply connectors (JPW1, JPW2 and JPW11) for connection to the ATX power supply. In addition, there are four power connectors for the GPU cards (JPW5-8). See Section 5-9 for power connector pin definitions.

### Connecting the Control Panel

JF1 contains header pins for various front control panel connectors. See Figure 5-1 for the pin locations of the various front control panel buttons and LED indicators.

All JF1 wires have been bundled into a single ribbon cable to simplify this connection. Make sure the red wire plugs into pin 1 as marked on the board. The other end connects to the Control Panel PCB board, located just behind the system status LEDs on the chassis. See Chapter 5 for details and pin descriptions.

Figure 5-1. Control Panel Header Pins

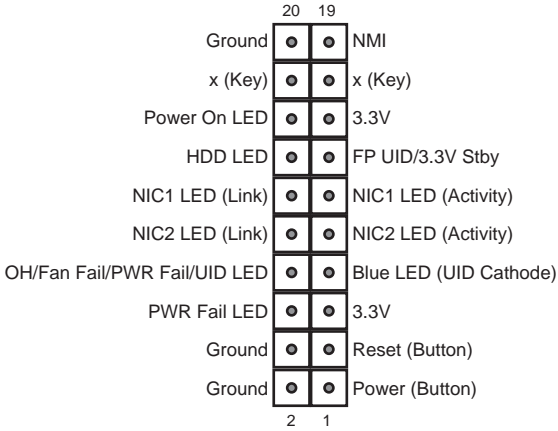

### 5-3 I/O Ports

The I/O ports are color coded in conformance with the PC 99 specification. See Figure 5-2 below for the colors and locations of the various I/O ports.

Figure 5-2. I/O Ports

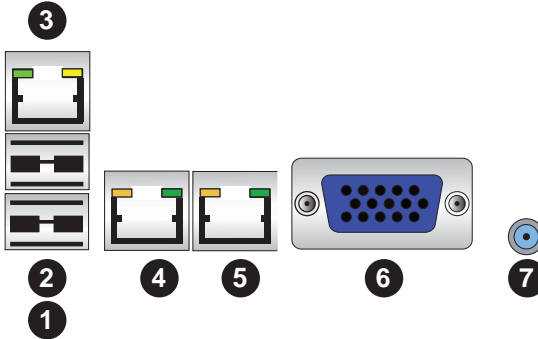

IO Ports	
1. USB Port 0	5. LAN Port 2
2. USB Port 1	6. VGA Port
3. IPMI Dedicated LAN	7. UID Switch
4. LAN Port 1	

**Note:** the LAN ports on the X9DRG-HTF+II are 10 Gb ports.

## 5-5 Installing the Processor and Heatsink

Avoid placing direct pressure to the top of the processor package. Always remove the power cord first before adding, removing or changing any hardware components.

### Notes:

- Always connect the power cord last and always remove it before adding, removing or changing any hardware components. Make sure that you install the processor into the CPU socket before you install the CPU heatsink.
- If you buy a CPU separately, make sure that you use an Intel-certified multi-directional heatsink only.
- Make sure to install the serverboard into the chassis before you install the CPU heatsinks.
- When receiving a serverboard without a processor pre-installed, make sure that the plastic CPU socket cap is in place and none of the socket pins are bent; otherwise, contact your retailer immediately.
- Refer to the Supermicro web site for updates on CPU support.

### Installing an LGA 2011 Processor

Follow the procedure below, beginning with the CPU1 socket.

1. There are two levers on the LGA 2011 socket. First press and release the load lever labeled 'Open 1st'.
2. Press the second load lever labeled 'Close 1st' to release the load plate from its locked position.

Press down on the lever labeled  
'Close 1st'

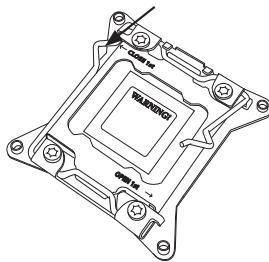

Pull lever away  
from the socket

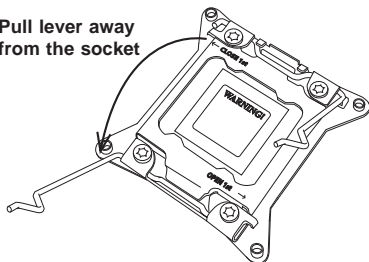

3. With the lever labeled 'Close 1st' fully retracted, gently push down on the 'Open 1st' lever to open the load plate. Lift the load plate to open it completely.
4. Using your thumb and the index finger, remove the 'WARNING' plastic cap from the socket.
5. Use your thumb and index finger to hold the CPU by its edges. Align the CPU keys, which are semi-circle cutouts, against the socket keys.
6. Once they are aligned, carefully lower the CPU straight down into the socket. (Do not drop the CPU on the socket. Do not move the CPU horizontally or vertically and do not rub the CPU against any pins of the socket, which may damage the CPU or the socket.)

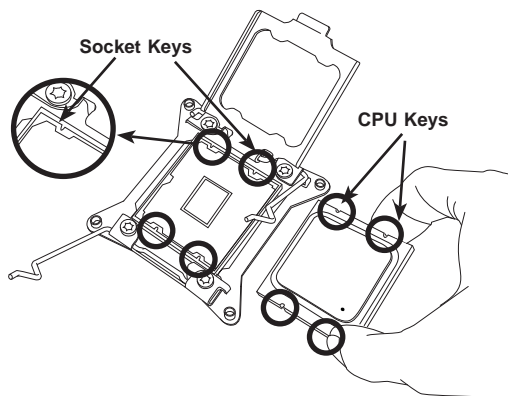
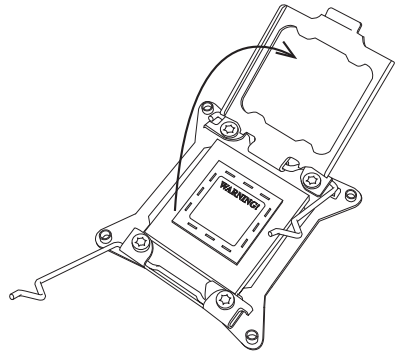
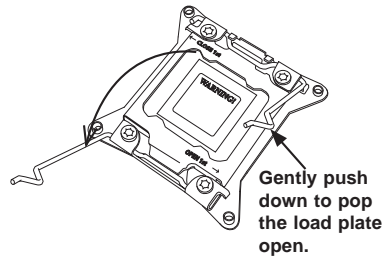

**Warning:** You can only install the CPU to the socket in one direction. Make sure that the CPU is properly inserted into the socket before closing the load plate. If it doesn't close properly, do not force it as it may damage your CPU. Instead, open the load plate again and double-check that the CPU is aligned properly.

7. With the CPU in the socket, inspect the four corners of the CPU to make sure that they are flush with the socket.
8. Close the load plate. Lock the lever labeled 'Close 1st', then lock the lever labeled 'Open 1st'. Use your thumb to gently push the load levers down until the lever locks.
9. Repeat the procedure to install a second processor in the CPU2 socket if desired.

**Note:** the PCI-E slots are controlled by the presence of a CPU. Slots will not be functional if the CPU that controls them is not installed. See Section 5-7 for details.

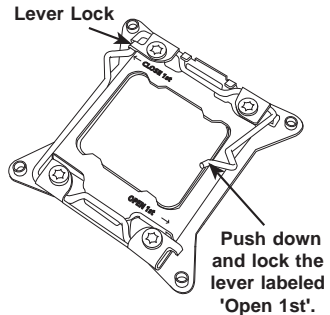
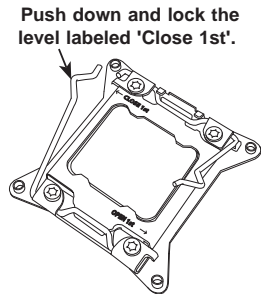
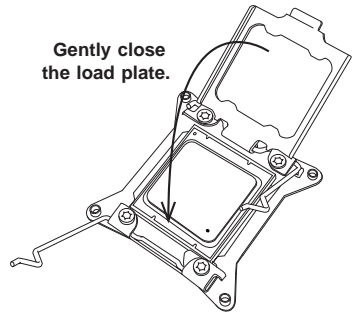

## Installing a CPU Heatsink

1. Remove power from the system and unplug the AC power cord from the power supply.
2. Do not apply any thermal grease to the heatsink or the CPU die; the required amount has already been applied.
3. Place the heatsink on top of the CPU so that the four mounting holes are aligned with those on the (preinstalled) heatsink retention mechanism.
4. Screw in two diagonal screws until just snug. Do not fully tighten the screws or you may damage the CPU.)
5. Add the two remaining screws then finish the installation by fully tightening all four screws.

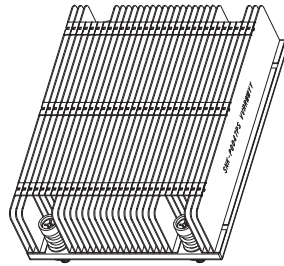

SNK-P0047PS (CPU1)

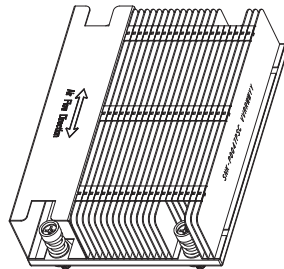

SNK-P0047PSC (CPU2)

## Removing the Heatsink

1. Unscrew and remove the heatsink screws from the serverboard in the sequence as show in the picture above.
2. Hold the heatsink and gently wiggle the heatsink back and forth to loosen it from the CPU. (Do not use excessive force when wiggling the heatsink.)
3. Once the heatsink is loose, remove it from the CPU socket.
4. Clean the surface of the CPU and the heatsink to get rid of the old thermal grease. Reapply the proper amount of thermal grease on the surface before you re-install a heatsink.

**Note:** see Chapter 6 for details on installing the air shroud.

## 5-6 Installing Memory

**Caution:** Exercise extreme care when installing or removing DIMM modules to prevent any possible damage.

### Memory Support

The X9DRG-HF+II/X9DRG-HFT+II supports up to 512 GB of registered ECC DDR3-1600/1333/1066 MHz RDIMMs or 128 GB of ECC/non-ECC UDIMMs in 16 DIMM slots. See the following tables for memory installation.

**Notes:** Memory speed support is dependent on the type of CPU used on the board.

### Installing Memory Modules

1. Insert the desired number of DIMMs into the memory slots, starting with P1-DIMM 1A. For best memory performance, please install memory modules of the same type and same speed on the memory slots as indicated on the tables below.
2. Insert each DIMM module vertically into its slot. Pay attention to the notch along the bottom of the module to avoid installing incorrectly (see Figure 5-4).
3. Gently press down on the DIMM module until it snaps into place in the slot. Repeat for all modules.

Figure 5-3. DIMM Installation

**To Install:** Insert module vertically and press down until it snaps into place. Pay attention to the alignment notch at the bottom.

**To Remove:** Use your thumbs to gently push the release tabs near both ends of the module. This should release it from the slot.

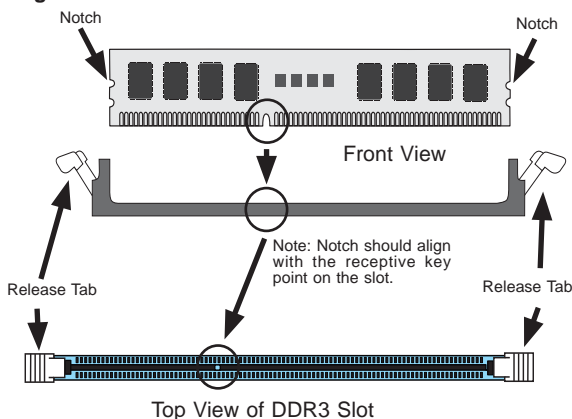



## Processor/DIMM Population Configurations

For memory to work properly, follow the tables below for memory installation.

- For memory to operate properly, please install DIMMs in pairs (have an even number of DIMMs installed).
- All channels in a system will run at the fastest common frequency.

Processors and their Corresponding Memory Modules								
CPU#	Corresponding DIMM Modules							
<b>CPU 1 P1-DIMM</b>	A1	A2	B1	B2	C1	C2	D1	D2
<b>CPU2 P2-DIMM</b>	E1	E2	F1	F2	G1	G2	H1	H2

Processor and Memory Module Population for Optimal Performance	
Number of CPUs+DIMMs	CPU and Memory Population Configuration Table (For memory to work properly, please follow the instructions below.)
<b>1 CPU &amp; 2 DIMMs</b>	CPU1 P1-DIMMA1/P1-DIMMB1
<b>1 CPU &amp; 4 DIMMs</b>	CPU1 P1-DIMMA1/P1-DIMMB1, P1-DIMMC1/P1-DIMMD1
<b>1 CPU &amp; 5-8 DIMMs</b>	CPU1 P1-DIMMA1/P1-DIMMB1, P1-DIMMC1/P1-DIMMD1 + Any memory pairs in P1-DIMMA2/P1-DIMMB2/P1-DIMMC2/P1-DIMMD2 slots
<b>2 CPUs &amp; 4 DIMMs</b>	CPU1 + CPU2 P1-DIMMA1/P1-DIMMB1, P2-DIMME1/P2-DIMMF1
<b>2 CPUs &amp; 6 DIMMs</b>	CPU1 + CPU2 P1-DIMMA1/P1-DIMMB1/P1-DIMMC1/P1-DIMMD1, P2-DIMME1/P2-DIMMF1
<b>2 CPUs &amp; 8 DIMMs</b>	CPU1 + CPU2 P1-DIMMA1/P1-DIMMB1/P1-DIMMC1/P1-DIMMD1, P2-DIMME1/P2-DIMMF1/P2-DIMMG1/P2-DIMMH1
<b>2 CPUs &amp; 10-16 DIMMs</b>	CPU1/CPU2 P1-DIMMA1/P1-DIMMB1/P1-DIMMC1/P1-DIMMD1, P2-DIMME1/P2-DIMMF1/P2-DIMMG1/P2-DIMMH1 + Any memory pairs in P1, P2 DIMM slots
<b>2 CPUs &amp; 16 DIMMs</b>	CPU1/CPU2 P1-DIMMA1/P1-DIMMB1/P1-DIMMC1/P1-DIMMD1, P2-DIMME1/P2-DIMMF1/P2-DIMMG1/P2-DIMMH1, P1-DIMMA2/P1-DIMMB2/P1-DIMMC2/P1-DIMMD2, P2-DIMME2/P2-DIMMF2/P2-DIMMG2/P2-DIMMH2

RDIMM Support POR				
DIMM Slots per Channel	DIMMs Populated per DDR Channel	RDIMM Type (RDIMM = Registered DIMMs)	POR Speeds (in MHz)	Ranks per DIMM (Any Combination)
1	1	Reg. ECC DDR3	1066/1333/1600	SR, DR, or QR
2	1	Reg. ECC DDR3	1066/1333/1600	SR, DR, or QR
2	2	Reg. ECC DDR3	1066/1333/1600	Mixing SR, DR, QR

**Population Rules:**

- Any combination of x4 and x8 RDIMMs with 1 Gb or 2 Gb DRAM density are supported.
- Populate DIMMs starting with DIMM A1.
- When mixing QR with SR or DR on the same DDR channel, put the QR in DIMMA1 first.

## 5-6 Expansion Cards

In addition to offering support for four GPU cards, the 1027GR-72RT2+/72R2+/TRT2+/TR2+ supports one low-profile PCI-Express 3.0 x8 expansion card (in x16 slot). A riser card is required to support expansion cards.

Refer to Chapter 6 for instructions on installing an expansion card in the system..

## 5-7 Serverboard Details

Figure 5-4. X9DRG-HF+II/ X9DRG-HTF+II Layout

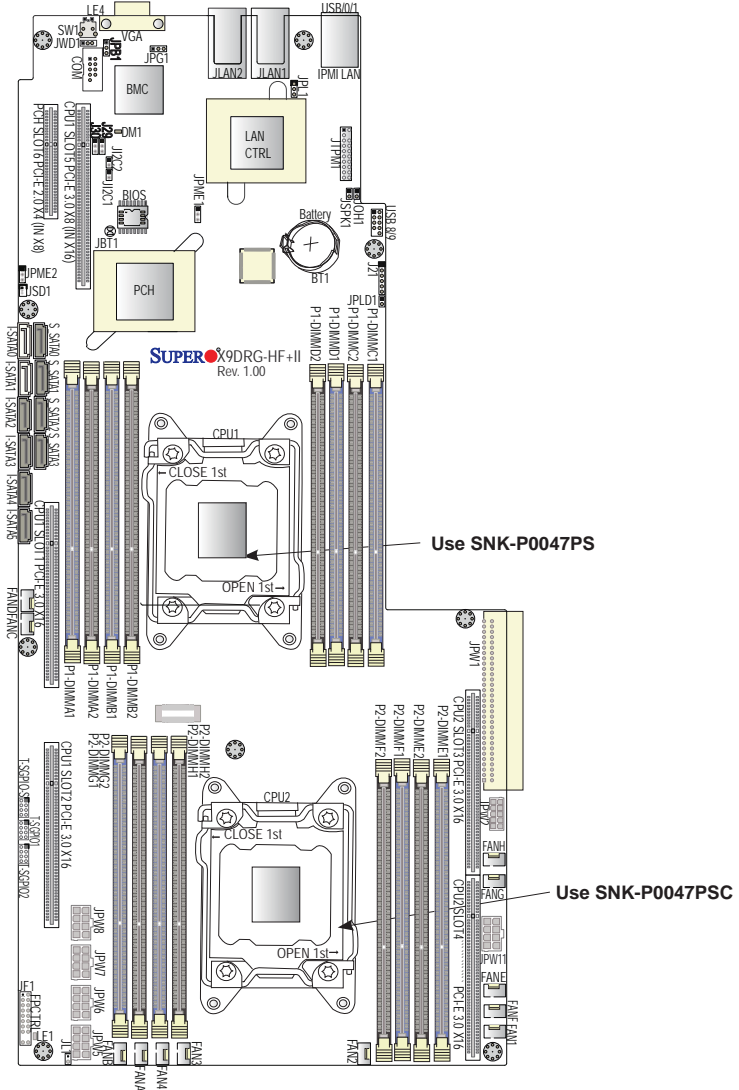

### Notes

Jumpers not indicated are for test purposes only.

"■" indicates the location of Pin 1.

The X9DRG-HTF+II supports two X540-based 10G LAN ports, the X9DRG-HF+II supports two I350-based 1G LAN ports.

## X9DRG-HF+II/ X9DRG-HTF+II Quick Reference

Jumper	Description	Default Setting
JBT1	Clear CMOS	See Section 5-9
JBR1	ME Recovery	Pins 2-3 (Normal)
JPB1	BMC Enable/Disable	Pins 1-2 (Enabled)
JPG1	VGA Enable/Disable	Pins 1-2 (Enabled)
JPL1	LAN1/LAN2 Enable/Disable	Pins 1-2 (Enabled)
JPME1	Manufacture Mode	Pins 1-2 (Normal)
JWD	Watch Dog Timer Enable/Disable	Pins 1-2 (Reset)
JWP1	Write-Protect Enable/Disable	Pins 1-2 (Enabled)

Connector	Description
Battery	Onboard Battery
FAN1 - FAN4	CPU Fans
FANA - FANH	GPU Fans
JCOM1	COM Header for Front Chassis Access
JF1	Control Panel Header
JL1	Chassis Intrusion Header
JOH1	Overheat LED Indicator
J <sup>2</sup> C1/J <sup>2</sup> C2	Power Supply SMBbus I <sup>2</sup> C Header
JPW1	Proprietary 62-pin Power Connector
JPW2	Proprietary 20-pin Power Connector
JPW3-8, JPW11	12V 8-pin Power Connectors
JPW9	Proprietary 38-pin Power Connector
JPW10	5V 4-pin Power Connector
JSD1	Power Fail Header
JSPK1	Onboard Speaker Header
JTPM1	TPM (Trusted Platform Module)/Port 80 Header
JRK1	SATA RAID Key Header
JVGA1	Backpanel VGA Port
LAN1/LAN2	LAN Ports 1/2 (1 GB on X9DRG-HF+, 10 GB on X9DRG-HTF+II)
(IPMI) LAN	IPMI Dedicated LAN

I-SATA 0~5	SATA 3.0 (I-SATA 0/1) and SATA 2.0 Ports (I-SATA 2~5)
S-SATA 0~3	SATA 2.0 Ports (S-SATA 0~3)
PCI Slot 1/Slot 2	PCI-E 3.0 x16 Slots (Available when CPU1 is populated)
PCI Slot 5	PCI-E 3.0 x8 in x16 Slot (Available when CPU1 is populated)
PCI Slot 3/Slot 4	PCI-E 3.0 x16 Slots (Available when CPU2 is populated)
(PCH) PCI Slot 6	PCI-E 2.0 x4 in x8 Slot (Available when CPU2 is populated)
SW1	UID Switch
T-SGPIO 1/2/S	Serial Link General Purpose I/O Headers
USB 0/1	Back Panel USB Ports

LED	Description	State/Status
DM1	BMC Heartbeat LED	Green: BMC Normal
LE1	Standby PWR LED	Green: SB Power On
LE4	UID Switch LED	

**Notes:**

PCI-E Slot 1, Slot 2 and Slot 5 are controlled by CPU1 and are only available when a processor is installed in CPU Socket 1. PCI-E Slot 3, Slot 4 and Slot 6 are controlled by CPU2 and are available only when a processor is installed in CPU Socket 2.

To provide adequate power supply to the system, be sure to connect all onboard power connectors to the power supply.

## 5-8 Connector Definitions

### Power Connectors

Three SMC-proprietary power connectors are located at JPW1, JPW2 and JPW9 to provide main power to the serverboard. Seven 12V, 8-pin power connectors, located at JPW3-8 and JPW11, are used for SATA devices and GPU cards (JPW5 is for the backplane). An additional 4-pin auxiliary connector is located at JPW10. Connect these power headers as described below.

12V 8-pin Power Connector Pin Definitions	
Pins	Definition
1 through 3	+12V
4 through 8	Ground

5V 4-pin Power Connector Pin Definitions	
Pins	Definition
1	+12V
2-3	Ground
4	+5V

JPW1: 62-pin SMC-Proprietary (Required)

JPW2: 20-pin SMC-Proprietary (Required)

JPW9: 38-pin SMC-Proprietary (Required)

JPW5: 12V 8-pin for HDD backplane (Required)

JPW3, 4, 6, 7, 8, 11: 12V 8-pin for GPU power

JPW10: 5V 4-pin Auxiliary

### Power Button Connector

The PW\_ON connector is on pins 1 and 2 of JF1. Momentarily contacting both pins will power on/off the system. This button can also be configured to function as a suspend button (with a setting in the BIOS, see Chapter 7). To turn off the power when set to suspend mode, press the button for at least 4 seconds. Refer to the table on the right for pin definitions. This header should be connected to the chassis power button. See the table on the right for pin definitions.

Power Button Pin Definitions (JF1)	
Pin#	Definition
1	Power Button
2	Ground

### Reset Connector

The reset connector is located on pins 3 and 4 of JF1 and attaches to the reset switch on the computer chassis. See the table on the right for pin definitions.

Reset Button Pin Definitions (JF1)	
Pin#	Definition
3	Reset
4	Ground

### Power Fail LED

The Power Fail LED connection is located on pins 5 and 6 of JF1. Refer to the table on the right for pin definitions.

PWR Fail LED Pin Definitions (JF1)	
Pin#	Definition
5	3.3V
6	PWR Fail LED

### Overheat/Fan Fail/UID LED

Connect an LED cable to pins 7 and 8 of JF1 for the Overheat/Fan Fail and UID LED connections. The red LED (pin 8) provides warning of an overheat or fan failure. The blue LED (pin 7) works as the UID LED indicator for the front panel UID button located on pins 13~14 of JF1. When Jumper J\_UID\_OW is set to off (default), the red LED takes precedence over the blue LED. Refer to the tables on the right for more information.

OH/Fan Fail/Blue_UID LED Pin Definitions (JF1)	
Pin#	Definition
7	Blue_LED-Cathode(UID)/5.5V.SB
8	OH/Fan Fail/UID LED (Red)

OH/Fan Fail LED Status (Red LED)	
State	Definition
Off	Normal
On	Overheat
Flashing	Fan Fail

### NIC2 (LAN2) LED

The LED connections for LAN2 are on pins 9 and 10 of JF1. Attach an LED cable to display network activity. See the table on the right for pin definitions.

NIC2 LED Pin Definitions (JF1)	
Pin#	Definition
9	Activity LED
10	Link LED

### NIC1 (LAN1) LED

The LED connections for LAN1 are on pins 11 and 12 of JF1. Attach an LED cable to display network activity. See the table on the right for pin definitions.

NIC1 LED Pin Definitions (JF1)	
Pin#	Definition
11	Activity LED
12	Link LED

### HDD/FP UID Button

The HDD/UID button connections are located on pins 13/14 of JF1. Attach a hard-drive LED cable to display HDD or SATA activity. This connection can also be used for the front panel UID (Unit Identifier) button. (The UID LED on pin 7 of JF1 works in conjunction with the UID button.) When the user presses and releases the UID button, the UID LED will be turned on or off to indicate the location of the unit in a stack or rackmounted servers.

HDD/UID LED Pin Definitions (JF1)	
Pin#	Definition
13	UID Signal/3.3V
14	HDD Activity

### Power On LED

The Power On LED connector is located on pins 15 and 16 of JF1. This connection is used to provide LED indication of power being supplied to the system. See the table on the right for pin definitions.

Power LED Pin Definitions (JF1)	
Pin#	Definition
15	+3.3V
16	Control

### Fan Headers

The X9DRG-HF+ has twelve fan headers. Fans 1~4 are for CPU/system use and Fans A~H for GPU use.. All are 4-pin fan headers, which are backward compatible with traditional 3-pin fans. However, fan speed control is available for 4-pin fans only. See the table on the right for pin definitions.

Fan Header Pin Definitions	
Pin#	Definition
1	Ground
2	+12V
3	Tachometer
4	Pulse Width Modulation

### Serial Ports

A COM Port (COM1) is located next to the UID switch to provide serial port support. See the table on the right for pin definitions.

Serial Port Pin Definitions			
Pin #	Definition	Pin #	Definition
1	DCD	6	DSR
2	RXD	7	RTS
3	TXD	8	CTS
4	DTR	9	RI
5	Ground	10	NC



### NMI Header

The non-maskable interrupt header is located at JNMI1. Refer to the table on the right for pin definitions.

NMI Button Pin Definitions	
Pin#	Definition
1	Control
2	Ground

### Internal Buzzer

The Speaker header, located at JSPK1, can be used to provide audible alarms for various beep codes. See the table on the right for pin definitions.

Internal Buzzer Pin Definitions		
Pin#	Definitions	
Pin 1	Pos. (+)	5V
Pin 2	Neg. (-)	Alarm Speaker

### Chassis Intrusion

A Chassis Intrusion header is located at JL1 on the serverboard. Attach an appropriate cable from the chassis to inform you of a chassis intrusion when the chassis is opened.

Chassis Intrusion Pin Definitions	
Pin#	Definition
1	Intrusion Input
2	Ground

### T-SGPIO Headers

Three SGPIO (Serial-Link General Purpose Input/Output) headers are provided on the serverboard. These headers support serial link interfaces for the onboard SATA ports. See the table on the right for pin definitions.

T-SGPIO Pin Definitions			
Pin#	Definition	Pin	Definition
1	NC	2	NC
3	Ground	4	Data
5	Load	6	Ground
7	Clock	8	NC

NC = No Connection

### RAIDKey Header

A RAIDKey header (JRK1) provides RAID function support to enhance system performance.

RAIDKey Pin Definitions	
Pin#	Definition
1	Ground
2	Signal
3	Ground

### TPM Header/Port 80

A Trusted Platform Module/Port 80 header is located at JTPM1 to provide TPM and Port 80 support, which will enhance system performance and data security. See the table on the right for pin definitions.

TPM/Port 80 Header Pin Definitions			
Pin#	Definition	Pin #	Definition
1	LCLK	2	GND
3	LFRAME#	4	<(KEY)>
5	LRESET#	6	NC
7	LAD 3	8	LAD 2
9	+3.3V	10	LAD1
11	LAD0	12	GND
13	NC	14	NC
15	+3V_DUAL	16	SERIRQ
17	GND	18	CLKRUN# (X)
19	LPCPD#	20	NC

### Universal Serial Bus (USB)

Two Universal Serial Bus ports (USB0/1) are located on the I/O backplane. Connect USB devices to these ports.

USB Pin Definitions	
Pin#	Definition
1	+5V
2	PO-
3	PO+
4	Ground
5	NA

### Ethernet Ports

Two Ethernet ports are located next to the USB 0/1 on the IO backplane. In addition, an IPMI Dedicated LAN is located above the USB ports 0/1. These ports accept RJ45 type cables.

**Notes:** The X9DRG-HTF+II supports two X540-based 10G LAN ports, the X9DRG-HF+ supports two I350-based 1G LAN ports. Please refer to the Onboard Indicator Section for LAN LED information.

LAN Ports Pin Definition			
Pin#	Definition	Pin#	Definitions
1	TD0+	11	TD3-
2	TD0-	12	PIV8_NIC
3	PIV8_NIC	13	ACT LED-
4	TD1+	14	ACT LED+
5	TD1-	15	Link 100 LED (Green)
6	PIV8_NIC	16	Link 1000 LED (Yellow)
7	TD2+	17	Ground
8	TD2-	18	Ground
9	PIV8_NIC	19	Ground
10	TD3+	20	Ground

## Unit Identifier Switch

A Unit Identifier (UID) switch and two LED indicators are provided on the serverboard. The rear UID LED (LE4) is located next to the rear UID switch. The front panel UID LED is on pins 7/8 of JF1. Connect a cable to pins 7/8 on JF1 for front panel UID indication. Pressing the UID switch will turn on both the rear and front UID LEDs. Pressing the UID switch again will turn off both LEDs. These UIDs provide easy identification of a system unit that may be in need of service.

**Note:** the UID can also be triggered via IPMI. Please refer to the IPMI User's Guide posted on our Website.

UID LED (LE4) Status		
Color/State	OS	Status
Blue: On	Windows OS	Unit Identified
Blue: Blinking	Linux OS	Unit Identified

UID Switch	
Pin#	Definition
1	Button In
2	Ground
3	Ground
4	Ground

## Overheat LED/Fan Fail

The JOH1 header is used to connect an LED indicator to provide warnings of chassis overheating and fan failure. This LED will blink when a fan failure occurs. Refer to the tables on right for pin definitions.

Overheat LED Pin Definitions	
Pin#	Definition
1	5vDC
2	OH Active

OH/Fan Fail LED Status	
State	Message
Solid	Overheat
Blinking	Fan Fail

## Power SMB (I<sup>2</sup>C) Connectors

Power System Management Bus (I<sup>2</sup>C) Connectors (JI<sup>2</sup>C1/JI<sup>2</sup>C2) monitor power supply, fan and system temperatures. See the table on the right for pin definitions.

PWR SMB Pin Definitions	
Pin#	Definition
1	Clock
2	Data
3	PWR Fail
4	Ground
5	+3.3V

## 5-9 Jumper Settings

### Explanation of Jumpers

To modify the operation of the serverboard, jumpers can be used to choose between optional settings. Jumpers create shorts between two pins to change the function of the connector. Pin 1 is identified with a square solder pad on the printed circuit board. See the serverboard layout pages for jumper locations.

**Note:** On a two-pin jumper, "Closed" means the jumper is on both pins and "Open" means the jumper is either on one pin or completely removed.

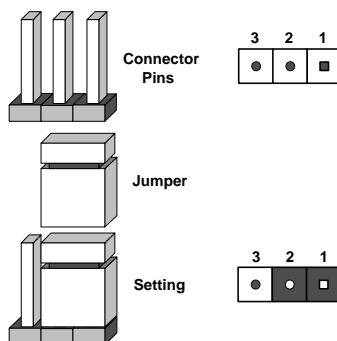

### CMOS Clear

JBT1 is used to clear CMOS (which will also clear any passwords). Instead of pins, this jumper consists of contact pads to prevent accidentally clearing the contents of CMOS.

#### To clear CMOS,

1. First power down the system and unplug the power cord(s).
2. With the power disconnected, short the CMOS pads with a metal object such as a small screwdriver.
3. Remove the screwdriver (or shorting device).
4. Reconnect the power cord(s) and power on the system.

**Note:** Do not use the PW\_ON connector to clear CMOS.

### VGA Enable/Disable

JPG1 allows you to enable or disable the VGA port. The default position is on pins 1 and 2 to enable VGA. See the table on the right for jumper settings.

VGA Enable/Disable Jumper Settings	
Jumper Setting	Definition
Pins 1-2	Enabled
Pins 2-3	Disabled

### LAN1/2 Enable/Disable

Change the setting of jumper JPL1 to enable or disable the LAN1/LAN2 Ethernet ports on the serverboard. See the table on the right for jumper settings. The default setting is enabled.

LAN1/2 Enable/Disable Jumper Settings	
Jumper Setting	Definition
Pins 1-2	Enabled
Pins 2-3	Disabled

### Watch Dog Enable/Disable

JWD controls the Watch Dog function. Watch Dog is a system monitor that can reboot the system when a software application hangs. Jumping pins 1-2 (default) will cause WD to reset the system if an application hangs. Jumping pins 2-3 will generate a non-maskable interrupt signal for the application that hangs. See the table on the right for jumper settings. Watch Dog must also be enabled in BIOS.

Watch Dog Jumper Settings	
Jumper Setting	Definition
Pins 1-2	Reset
Pins 2-3	NMI
Open	Disabled

**Note:** When enabled, the user needs to write their own application software in order to disable the Watch Dog Timer.

### Manufacturer Mode Select

Close jumper JPME1 to bypass SPI flash security and force the system to use the Manufacturer Mode, which will allow the user to flash the system firmware from a host server to modify system settings. See the table on the right for jumper settings.

ME Mode Select Jumper Settings	
Jumper Setting	Definition
1-2	Normal (Default)
2-3	Manufacture Mode

### Write Protect Enable

Close pins 1/2 of jumper JWP1 to enable Write Protect support for system security and data integrity. See the table on the right for jumper settings.

Write Protect Jumper Settings	
Jumper Setting	Definition
Pins 1/2	Write_Protect Enable (Default)
Pins 2/3	Write_Protect Disable

### BMC Enable/Disable

Use jumper JPB1 to enable or disable the BMC (Baseboard Management Controller), which supports IPMI 2.0/KVM. See the table on the right for jumper settings.

BMC Enable/Disable Jumper Settings	
Both Jumpers	Definition
Pins 1-2	Enabled
Pins 2-3	Disabled

## 5-10 Onboard Indicators

### LAN1/2 Port LEDs

The Ethernet ports have two LEDs. On each port, one LED indicates activity while the other LED may be green, amber or off to indicate the speed of the connection. See the table on the right for the functions associated with the connection speed LED.

**Note:** the dedicated IPMI LAN does not operate at 1 Gb/s.

LAN1/2 LED (Connection Speed Indicator)	
LED Color	Definition
Off	No connection or 10/100 Mb/s
Green	1 Gb/s
Amber	10 Gb/s (X9DRG-HTF+II only)

### Dedicated IPMI LAN Port LEDs

A dedicated IPMI LAN port is also located on the I/O backplane. The amber LED on the right indicates activity, while the green LED on the left indicates the speed of the connection. Please note that the IPMI LAN does not support 1Gbps connections. See the table at right for more information.

IPMI LAN LEDs		
LED	Color/State	Definition
Link (Left)	Green: Solid	100 Mbps
Activity (Right)	Amber: Blinking	Active

### Onboard Power LED

An Onboard Power LED is located at LE1. This LED Indicator is on when the system is on. Be sure to unplug the AC power cable before removing or adding any components. See the table on the right for more details.

Onboard PWR LED Indicator	
LED Color	Definition
Off	System Off (power cable not connected)
Green	System On
Green: Flashing Quickly	ACPI S1 State

## ME Recovery

JBR1 is used for ME Firmware Recovery mode, which will limit system resources for essential function use only without putting restrictions on power use. In the single operation mode, online upgrade will be available via Recovery mode. See the table on the right for jumper settings.

ME Recovery Select Jumper Settings	
Jumper Setting	Definition
1-2	Manufacture Mode
2-3	Normal (Default)

## BMC Heartbeat LED

The BMC Heartbeat LED is designated DM1. When DM1 is blinking, the BMC (Baseboard Management Controller) is functioning normally. See the table at right for more information.

BMC Heartbeat LED Indicator LED Status	
Green: Blinking	BMC: Normal

## Rear UID LED

The rear UID LED is located at LE4 on the backplane. This LED is used in conjunction with the rear UID switch to provide easy identification of a system that might be in need of service.

UID LED Status		
Color/State	OS	Status
Blue: On	Windows OS	Unit Identified
Blue: Blinking	Linux OS	Unit Identified

## 5-11 SATA Ports

### SATA Ports

Two SATA 3.0 ports (I-SATA0 and I-SATA1) and eight SATA 2.0 ports (I-SATA2 through I-SATA5 and S-SATA0 through S-SATA3) are included on the serverboard. There are no jumpers to configure the onboard SATA ports. See the table on the right for pin definitions.

SATA Port Pin Definitions	
Pin #	Definition
1	Ground
2	TXP
3	TXN
4	Ground
5	RXN
6	RXP
7	Ground

## 5-12 Installing Software

The Supermicro ftp site contains drivers and utilities for your system at <ftp://ftp.supermicro.com>. Some of these must be installed, such as the chipset driver.

After accessing the ftp site, go into the CDR\_Images directory and locate the ISO file for your motherboard. Download this file to create a CD/DVD of the drivers and utilities it contains. (You may also use a utility to extract the ISO file if preferred.)

Another option is to go to the Supermicro Website at <http://www.supermicro.com/products/>. Find the product page for your motherboard here, where you may download individual drivers and utilities.

After creating a CD/DVD with the ISO files, insert the disk into the CD/DVD drive on your system and the display shown in Figure 5-5 should appear.

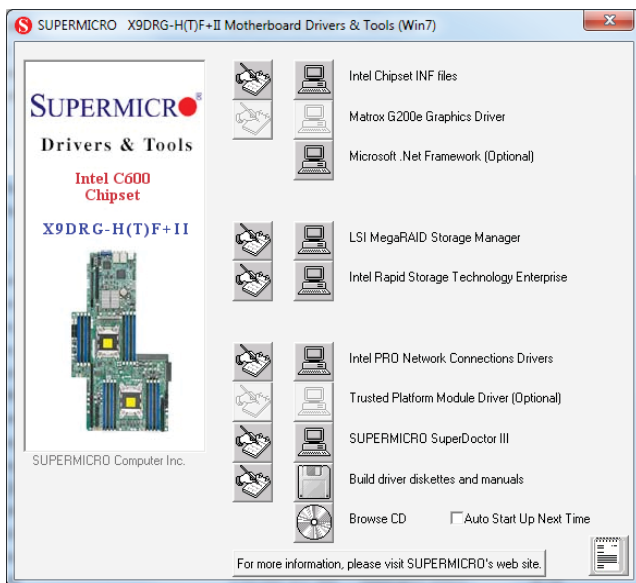

Figure 5-5. SuperDoctor III Interface Display Screen (Health Information)

**Note:** Click the icons showing a hand writing on paper to view the readme files for each item. Click the computer icons to the right of these items to install each item (from top to the bottom) one at a time. **After installing each item, you must re-boot the system before moving on to the next item on the list.** The bottom icon with a CD on it allows you to view the entire contents of the CD.



## SuperDoctor III

The SuperDoctor® III program is a web-based management tool that supports remote management capability. It includes Remote and Local Management tools. The local management is called SD III Client. The SuperDoctor III program allows you to monitor the environment and operations of your system. SuperDoctor III displays crucial system information such as CPU temperature, system voltages and fan status. See the figures below for examples of the SuperDoctor III interface.

**Note:** The default User Name and Password for SuperDoctor III is ADMIN / ADMIN.

**Note:** When SuperDoctor III is first installed, it adopts the temperature threshold settings that have been set in BIOS. Any subsequent changes to these thresholds must be made within SuperDoctor III, as the SuperDoctor III settings override the BIOS settings. To set the BIOS temperature threshold settings again, you would first need to uninstall SuperDoctor III.

Figure 5-6. SuperDoctor III Interface Display Screen (Remote Control)

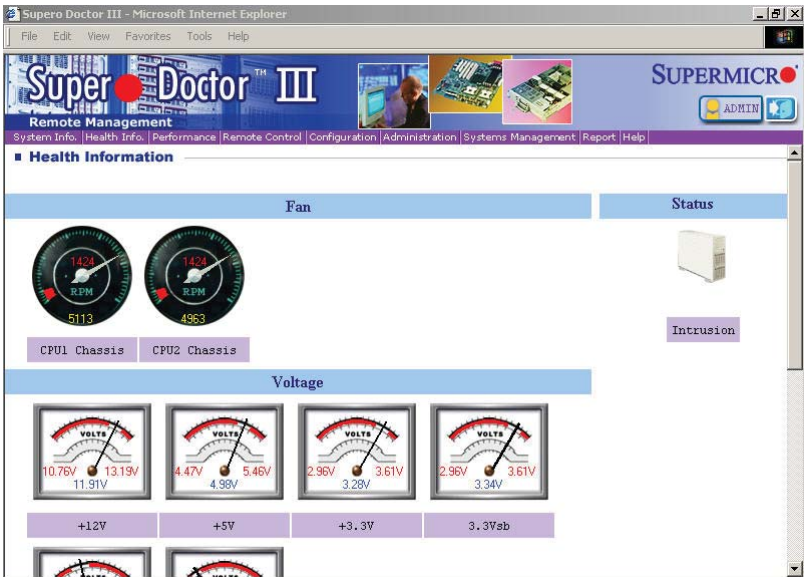
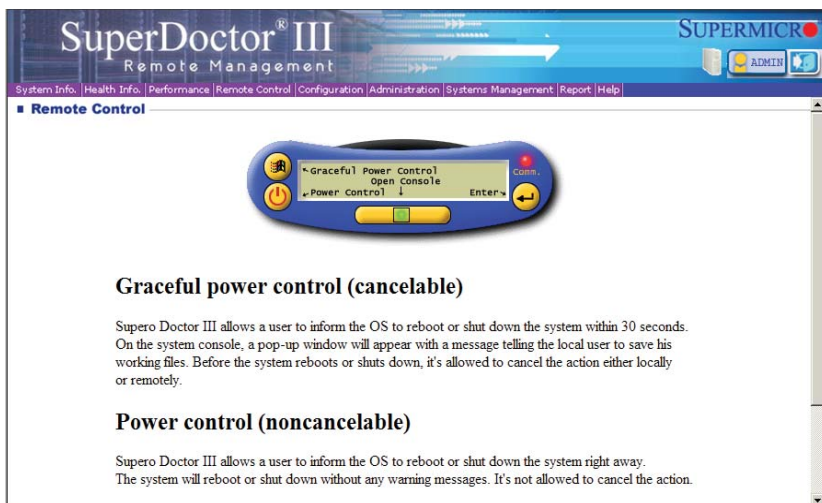

Figure 5-7. SuperDoctor III Interface Display Screen (Remote Control)



**Note:** The SuperDoctor III program and User's Manual can be downloaded from the Supermicro web site at <http://www.supermicro.com/products/accessories/software/SuperDoctorIII.cfm>. For Linux, we recommend that you use the SuperDoctor II application instead.

## 5-13 Onboard Battery

Care must be taken to assure that the chassis cover is in place when the system is operating to ensure proper cooling. Out of warranty damage to the system can occur if this practice is not strictly followed.

**Figure 5-8. Installing the Onboard Battery**

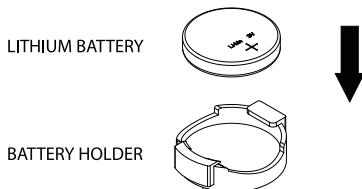

Please handle used batteries carefully. Do not damage the battery in any way; a damaged battery may release hazardous materials into the environment. Do not discard a used battery in the garbage or a public landfill. Please comply with the regulations set up by your local hazardous waste management agency to dispose of your used battery properly.

## Notes

## Chapter 6

### Advanced Chassis Setup

This chapter covers the steps required to install components and perform maintenance on the SC118GH chassis. For component installation, follow the steps in the order given to eliminate the most common problems encountered. If some steps are unnecessary, skip ahead to the next step.

**Tools Required:** The only tool you will need to install components and perform maintenance is a Philips screwdriver.

#### 6-1 Static-Sensitive Devices

Electrostatic Discharge (ESD) can damage electronic components. To prevent damage to any printed circuit boards (PCBs), it is important to handle them very carefully.

The following measures are generally sufficient to protect your equipment from ESD damage.

##### Precautions

- Use a grounded wrist strap designed to prevent static discharge.
- Touch a grounded metal object before removing any board from its antistatic bag.
- Handle a board by its edges only; do not touch its components, peripheral chips, memory modules or gold contacts.
- When handling chips or modules, avoid touching their pins.
- Put the serverboard, add-on cards and peripherals back into their antistatic bags when not in use.
- For grounding purposes, make sure your computer chassis provides excellent conductivity between the power supply, the case, the mounting fasteners and the serverboard.

Figure 6-1. Chassis: Front and Rear Views

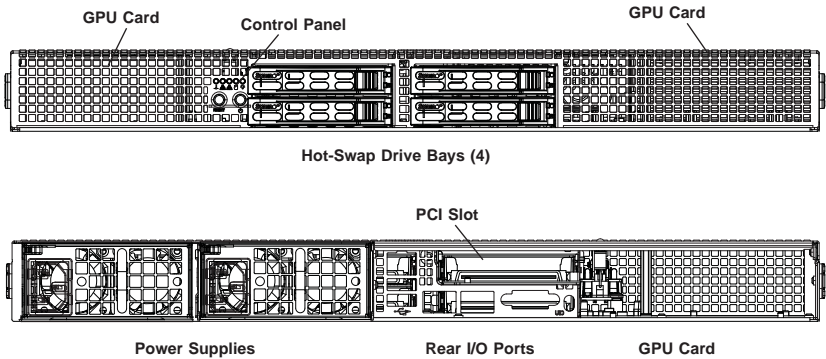

**Note:** the number of PCI slots available depends on the presence of GPUs in the server model.

## 6-2 Control Panel

The control panel (located on the front of the chassis) must be connected to the JF1 connector on the serverboard to provide you with system status indications. A ribbon cable has bundled these wires together to simplify the connection. Connect the cable from JF1 on the serverboard to the appropriate header on the Control Panel PCB (printed circuit board). Make sure the red wire plugs into pin 1 on both connectors. Pull all excess cabling out of the airflow path.

The control panel LEDs inform you of system status. See "Chapter 3: System Interface" for details on the LEDs and the control panel buttons. Details on JF1 can be found in "Chapter 5: Advanced Serverboard Installation."

## 6-3 System Cooling

Ten 4-cm counter-rotating fans provide the cooling for the system. Each fan unit is actually made up of two fans joined back-to-back, which rotate in opposite directions. This counter-rotating action generates exceptional airflow and works to dampen vibration levels.

It is very important that the chassis top cover is properly installed and making a good seal in order for the cooling air to circulate properly through the chassis and cool the components.

## System Fan Failure

Fan speed is controlled by system temperature via IPMI. If a fan fails, the remaining fans will ramp up to full speed. Replace any failed fan at your earliest convenience with the same type and model (the system can continue to run with a failed fan). Failed fans can be identified through the BIOS. (See the fan numbering in Figure 6-3. These numbers are also imprinted on the floor of the chassis.)

### *Replacing a System Fan*

1. If the BIOS is not being utilized to determine which fan has failed, open the top cover of the chassis while the system is running to locate the position of the failed fan. Never run the server for an extended period of time with the top cover open.
2. Turn off the power to the system and unplug the AC power cord.
3. Remove the failed fan's wiring from the serverboard.
4. Remove the four pins securing the fan to the fan tray.
5. Lift the failed fan from the fan tray and out of the chassis.
6. Place the new fan into the vacant space in the fan tray, while making sure the arrows on the top of the fan (indicating air direction) point in the same direction as the arrows on the other fans in the same fan tray.
7. Reconnect the fan wires to the exact same chassis fan headers as the previous fan.
8. Reconnect the AC power cord, power up the system and check that the fan is working properly before replacing the chassis cover.

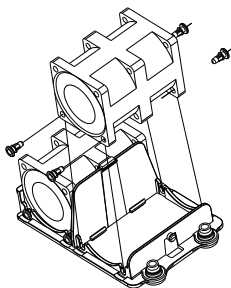

**Figure 6-2. Removing a Fan from the Fan Tray**

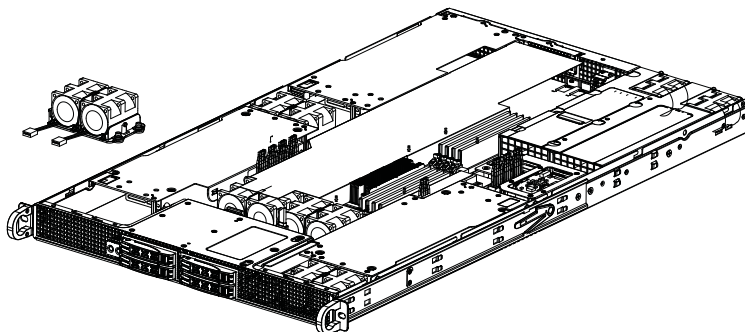

Figure 6-3: Installing a Fan

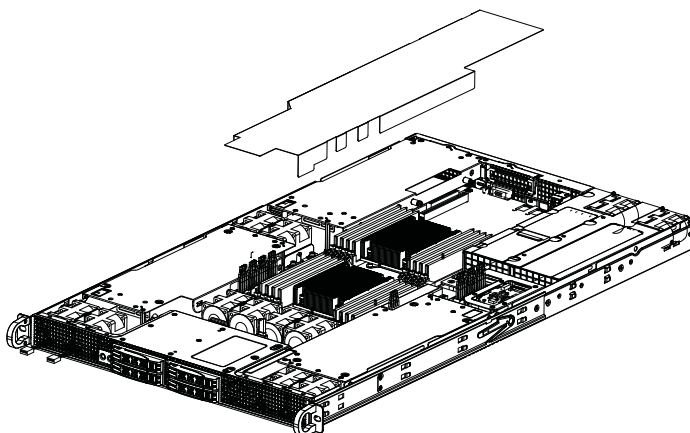

Figure 6-4: Installing the Air Shroud

## Installing the Air Shroud

Air shrouds concentrate airflow to maximize fan efficiency. The SC118GH chassis air shroud does not require screws to set up.

Note: Each GPU card has its own air shroud.

### *Installing the Air Shroud*

1. Position the air shroud in the chassis as illustrated in Figure 6-4.
2. Align the notch on the air shroud with the pin on the add-on card bracket.
3. Slide the pin into the back of the notch.
4. Lower the front of the air shroud over the fan tray, sliding the front notches over the pins on the fan tray.



## Installing Graphics (GPU) Cards

The system supports three GPU cards, which are mounted in brackets to fit into the PCI-E 3.0 slots at the front of the chassis. NVIDIA Fermi M2090, Fermi M2075, NVIDIA Kepler K10 and Kepler GRID K1 and K2 GPUs are supported.

The GPU cards may be preinstalled. The procedure below is provided for when a GPU card needs to be replaced. See NVIDIA's web site for more details on the K10 GPU specifications.

### *Installing Graphics Cards*

1. Identify the left and right brackets and graphics cards as illustrated below.
2. Insert the graphics cards into the brackets, aligning the mounting holes in the cards with those in the brackets. Kepler cards require a different bracket than Fermi cards (MCP-240-00117-0N). The system comes with Fermi brackets already installed by default. If replacing Fermi GPUs with Kepler GPUs, remove the Fermi brackets from the chassis and replace with the Kepler brackets.
3. Secure each card to the bracket using the screws that are included for this purpose. Keplers: remove the bracket on the end of the GPU, add a washer (included in kit) between the plate and the pcb for each screw, then attach the GPU to the system Kepler bracket (MCP-240-00117-0N), which now takes the place of the Fermi bracket.
4. Carefully position each bracket in the chassis as illustrated below, aligning the four mounting holes in the top and side of each bracket with the corresponding mounting holes in the chassis. Pay attention to the airflow arrows to install each card into the correct side of the chassis
5. Secure the bracket to the chassis by using the screws provided.
6. After a GPU card is installed, you must connect it to one of the following power headers on the serverboard: JPW3, JPW4, JPW6, JPW7, JPW8 or JPW11.

**Important Note for Kepler GPUs:** note the airflow arrows on top of the GPU card. The card with the arrow pointing toward the Tesla logo should go on the left side of the chassis, and the card with the arrow pointing away from the Tesla logo should go on the right side of the chassis (when viewed from the front of the system). The Kepler GPU card brackets need two additional washers added (see note on previous page).

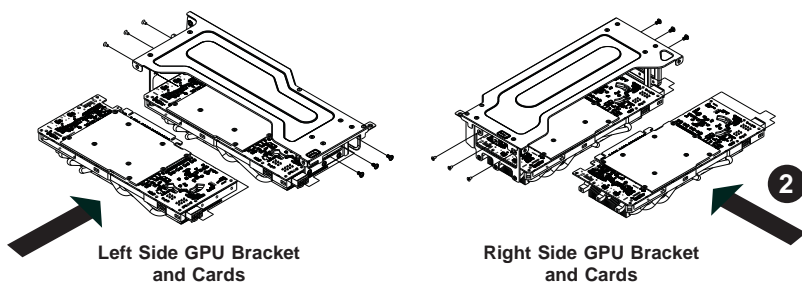
**Figure 6-5. Installing GPU Cards into the Left and Right GPU Brackets**

## 6-4 Drive Bay Installation/Removal

### Accessing the Drive Bays

Because of their hotswap capability, you do not need to access the inside of the chassis or power down the system to install or replace hard drives. Proceed to the next section for instructions.

### Hard Drive Installation

The hard drives are mounted in drive carriers to simplify their installation and removal from the chassis. These carriers also help promote proper airflow for the drive bays. For this reason, even empty carriers without drives installed must remain in the chassis.

#### *Removing Hard Drive Carriers from the Chassis*

1. Press the release button on the drive carrier. This extends the drive carrier handle.
2. Use the handle to pull the drive carrier out of the chassis.

#### *Installing a Hard Drive into a Drive Carrier*

1. Remove the dummy drive, which comes pre-installed in the drive carrier, by removing the screws securing the dummy drive to the carrier. Note that these screws cannot be reused on the actual 2.5" hard drive.
2. Insert a drive into the carrier with the PCB side facing down and the connector end toward the rear of the carrier.

3. Align the drive in the carrier so that the screw holes of both line up. Note that there are holes in the carrier marked "SATA" to aid in correct installation.
4. Secure the drive to the carrier with four M3 screws as illustrated below. These screws are included in the chassis accessory box.
5. Insert the drive carrier into its bay, keeping the carrier oriented so that the hard drive is on the top of the carrier and the release button is on the right side. When the carrier reaches the rear of the bay, the release handle will retract.
6. Push the handle in until it clicks into its locked position

**Warning:** Except for short periods of time (e.g. when swapping hard drives), do not operate the server with the hard drive carriers removed.

**Figure 6-6. Removing a Hard Drive Carrier**

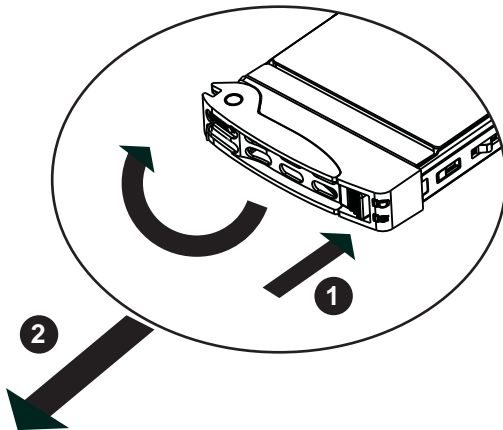

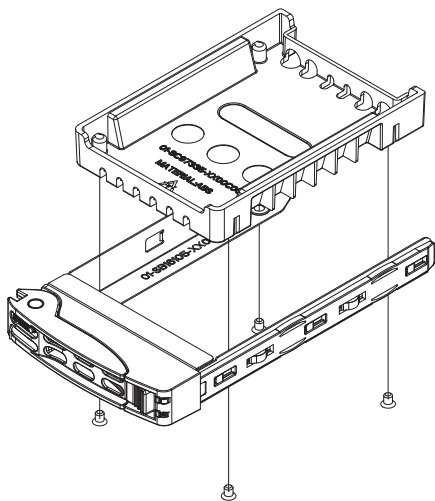

**Figure 6-7. Installing a Hard Drive into a Carrier**

Enterprise level hard disk drives are recommended for use in Supermicro chassis and servers. For information on recommended HDDs, visit the Supermicro Web site at <http://www.supermicro.com/products/nfo/storage.cfm>

## 6-5 Power Supply

The 1027GR-72RT2+/72R2+/TRT2+/TR2+ series server includes a redundant 1600 watt power supply. The power supply module has an auto-switching capability, which enables it to automatically sense and operate at a 100V - 240V input voltage.

If either of the two power supply modules fail, the other module will take the full load and allow the system to continue operation without interruption. The PWR Fail LED will illuminate and remain on until the failed unit has been replaced. Replacement units can be ordered directly from Supermicro. The power supply units have a hot-swap capability, meaning you can replace the failed unit without powering down the system.

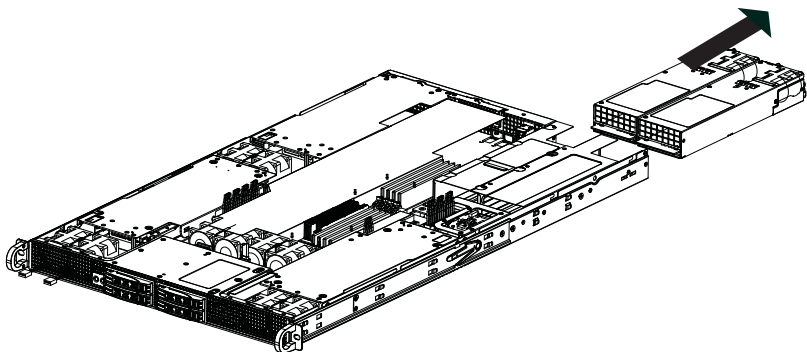

**Figure 6-8. Removing the Power Supply**

### *Replacing the Power Supply*

1. First unplug the AC power cord from the failed power supply module.
2. To remove the failed power unit, push in the locking tab at the back of the module to release it. You can then pull the unit straight out of the chassis.
3. Replace the failed unit with another of the exact same power supply.
4. Carefully insert the new unit into position in the chassis and secure it with the screws at the rear of the unit.
5. Reconnect the power cord and push the unit back into the rack.

## Notes

## Chapter 7

### BIOS

#### 7-1 Introduction

This chapter describes the AMI BIOS Setup utility for the X9DRG-HF+II/X9DRG-HTF+II. It also provides the instructions on how to navigate the AMI BIOS Setup utility screens. The AMI ROM BIOS is stored in a Flash EEPROM and can be easily updated.

#### Starting BIOS Setup Utility

To enter the AMI BIOS Setup utility screens, press the <Del> key while the system is booting up.

**Note:** In most cases, the <Del> key is used to invoke the AMI BIOS setup screen. There are a few cases when other keys are used, such as <F3>, <F4>, etc.

Each main BIOS menu option is described in this manual. The Main BIOS setup menu screen has two main frames. The left frame displays all the options that can be configured. Grayed-out options cannot be configured. Options in blue can be configured by the user. The right frame displays the key legend. Above the key legend is an area reserved for a text message. When an option is selected in the left frame, it is highlighted in white. Often a text message will accompany it.

**Note:** The AMI BIOS has default text messages built in. The manufacturer retains the option to include, omit, or change any of these text messages.

The AMI BIOS Setup utility uses a key-based navigation system called "hot keys." Most of the AMI BIOS setup utility "hot keys" can be used at any time during setup navigation. These keys include <F3>, <F4>, <Enter>, <ESC>, arrow keys, etc.

**Notes:** Options printed in **Bold** are default settings. <F3> is used to load optimal default settings. <F4> is used to save the settings and exit the setup utility.

## How To Change the Configuration Data

The configuration data that determines the system parameters may be changed by entering the AMI BIOS Setup utility. This Setup utility can be accessed by pressing <Delete> at the appropriate time during system boot.

**Note:** For AMI UEFI BIOS Recovery, please refer to the UEFI BIOS Recovery User Guide posted @<http://www.supermicro.com/support/manuals/>.

## Starting the Setup Utility

Normally, the only visible Power-On Self-Test (POST) routine is the memory test. As the memory is being tested, press the <Delete> key to enter the main menu of the AMI BIOS Setup utility. From the main menu, you can access the other setup screens. An AMI BIOS identification string is displayed at the left bottom corner of the screen below the copyright message.

**Warning:** Do not upgrade the BIOS unless your system has a BIOS-related issue. Flashing the wrong BIOS can cause irreparable damage to the system. In no event shall the manufacturer be liable for direct, indirect, special, incidental, or consequential damage arising from a BIOS update. If you have to update the BIOS, do not shut down or reset the system while the BIOS is being updated to avoid possible boot failure.

## 7-2 Main Setup

When you first enter the AMI BIOS Setup utility, you will enter the Main setup screen. You can always return to the Main setup screen by selecting the Main tab on the top of the screen. The Main BIOS Setup screen is shown below.

The AMI BIOS Main menu displays the following information:





**System Date/System Time**

Use this option to change the system date and time. Highlight *System Date* or *System Time* using the arrow keys. Enter new values through the keyboard and press <Enter>. Press the <Tab> key to move between fields. The date must be entered in Day MM/DD/YY format. The time is entered in HH:MM:SS format. (**Note:** The time is in the 24-hour format. For example, 5:30 P.M. appears as 17:30:00.).

**Supermicro X9DRG-HF+II****Version**

This item displays the SMC version of the BIOS ROM used in this system.

**Build Date**

This item displays the date that the BIOS Setup utility was built.

**Memory Information****Total Memory**

This displays the amount of memory that is available in the system.

## 7-3 Advanced Setup Configurations

Select the Advanced tab to access the following submenu items.

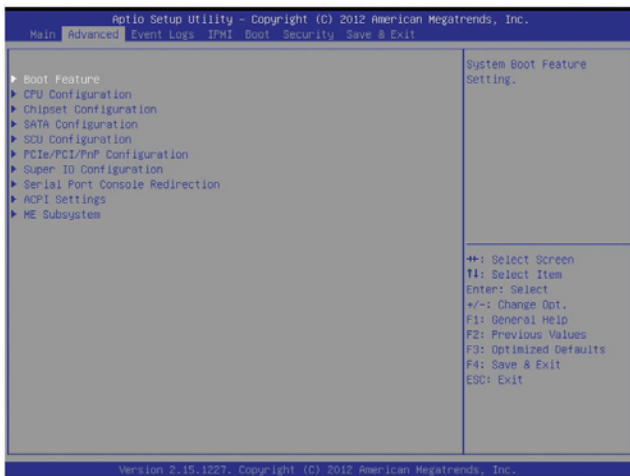

### ► Boot Features

#### Quiet Boot

This feature allows the user to select bootup screen display between POST messages and the OEM logo. Select Disabled to display the POST messages. Select Enabled to display the OEM logo instead of the normal POST messages. The options are **Enabled** and Disabled.

#### AddOn ROM Display Mode

Use this item to set the display mode for the Option ROM. Select Keep Current to use the current AddOn ROM Display setting. Select Force BIOS to use the Option ROM display mode set by the system BIOS. The options are **Force BIOS** and Keep Current.

#### Bootup Num-Lock

Use this feature to set the Power-on state for the Numlock key. The options are Off and **On**.

#### Wait For 'F1' If Error

Select Enabled to force the system to wait until the 'F1' key is pressed if an error occurs. The options are Disabled and **Enabled**.

### **Interrupt 19 Capture**

Interrupt 19 is the software interrupt that handles the boot disk function. When this item is set to Enabled, the ROM BIOS of the host adaptors will "capture" Interrupt 19 at bootup and allow the drives that are attached to these host adaptors to function as bootable disks. If this item is set to Disabled, the ROM BIOS of the host adaptors will not capture Interrupt 19, and the drives attached to these adaptors will not function as bootable devices. The options are **Enabled** and Disabled.

## **Power Configuration**

### **Watch Dog Function**

If enabled, the Watch Dog timer will allow the system to reboot when it is inactive for more than 5 minutes. The options are Enabled and **Disabled**.

### **Power Button Function**

If this feature is set to Instant Off, the system will power off immediately as soon as the user presses the power button. If this feature is set to 4 Seconds Override, the system will power off when the user presses the power button for 4 seconds or longer. The options are **Instant Off** and 4 Seconds Override.

### **Restore on AC Power Loss**

Use this feature to set the power state after a power outage. Select Stay Off for the system power to remain off after a power loss. Select Power On for the system power to be turned on after a power loss. Select Last State to allow the system to resume its last state before a power loss. The options are Power On, Stay Off, and **Last State**.

## **►CPU Configuration**

This submenu displays the information of the CPU as detected by the BIOS. It also allows the user to configuration CPU settings.

### **►Socket 1 CPU Information/Socket 2 CPU Information**

This submenu displays the following information regarding the CPUs installed in Socket 1/ Socket 2.

- Type of CPU
- CPU Signature
- Microcode Patch

- CPU Stepping
- Maximum CPU Speed
- Minimum CPU Speed
- Processor Cores
- Intel HT (Hyper-Threading) Technology
- Intel VT-x Technology
- Intel SMX Technology
- L1 Data Cache
- L1 Code Cache
- L2 Cache
- L3 Cache

### **CPU Speed**

This item displays the speed of the CPU installed in Socket 1/Socket 2.

### **64-bit**

This item indicates if the CPU installed in Socket 1 or Socket 2 supports 64-bit technology.

### **Clock Spread Spectrum**

Select Enable to enable Clock Spectrum support, which will allow the BIOS to monitor and attempt to reduce the level of Electromagnetic Interference caused by the components whenever needed. The options are **Disabled** and Enabled.

### **RTID (Record Types IDs)**

This feature displays the total number of Record Type IDs for local and remote pools. The options are **Optimal** and Alternate.

### **Hyper-threading**

Select Enabled to support Intel Hyper-threading Technology to enhance CPU performance. The options are **Enabled** and Disabled.

**Active Processor Cores**

Set to Enabled to use a processor's second core and above. (Please refer to Intel's website for more information.) The options are **All**, 1, 2, 4 and 6.

**Limit CPUID Maximum**

This feature allows the user to set the maximum CPU ID value. Enable this function to boot the legacy operating systems that cannot support processors with extended CPUID functions. The options are Enabled and **Disabled** (for the Windows OS).

**Execute Disable Bit (Available if supported by the OS & the CPU)**

Select Enabled to enable the Execute Disable Bit which will allow the processor to designate areas in the system memory where an application code can execute and where it cannot, thus preventing a worm or a virus from flooding illegal codes to overwhelm the processor or damage the system during an attack. The default is **Enabled**. (Refer to Intel and Microsoft Web sites for more information.)

**Intel® AES-NI**

Select Enable to use the Intel Advanced Encryption Standard (AES) New Instructions (NI) to ensure data security. The options are **Enabled** and Disabled.

**MLC Streamer Prefetcher (Available when supported by the CPU)**

If set to Enabled, the MLC (mid-level cache) streamer prefetcher will prefetch streams of data and instructions from the main memory to the L2 cache to improve CPU performance. The options are Disabled and **Enabled**.

**MLC Spatial Prefetch (Available when supported by the CPU)**

If this feature is set to Disabled, The CPU prefetches the cache line for 64 bytes. If this feature is set to Enabled the CPU fetches both cache lines for 128 bytes as comprised. The options are Disabled and **Enabled**.

**DCU Streamer Prefetcher (Available when supported by the CPU)**

If this feature is set to Enabled, the Data Cache Unit (DCU) will prefetch L1 data to speed up data accessing and processing in the DCU to enhance CPU performance. The options are Disabled and **Enabled**.

**DCU IP Prefetcher**

Select Enabled for DCU (Data Cache Unit) IP Prefetcher support, which will prefetch IP addresses to improve network connectivity and system performance. The options are **Enabled** and Disabled.

**Intel® Virtualization Technology (Available when supported by the CPU)**

Select Enabled to support Intel Virtualization Technology, which will allow one platform to run multiple operating systems and applications in independent partitions, creating multiple "virtual" systems in one physical computer. The options are **Enabled** and Disabled.

**Note:** If there is any change to this setting, you will need to power off and restart the system for the change to take effect. Please refer to Intel's website for detailed information.)

**► CPU Power Management Configuration**

This submenu allows the user to configure the following CPU Power Management settings.

**Power Technology**

Select Energy Efficiency to support power-saving mode. Select Custom to customize system power settings. Select Disabled to disable power-saving settings. The options are Disabled, **Energy Efficient**, and Custom. If the option is set to Custom, the following items will display:

**EIST (Available when Power Technology is set to Custom)**

EIST (Enhanced Intel SpeedStep Technology) allows the system to automatically adjust processor voltage and core frequency to reduce power consumption and heat dissipation. The options are Disabled (GV3 Disabled), and **Enabled (GV3 Enabled)**. (**Note:** GV3 is Intel Speedstep support used on older platforms. Please refer to Intel's website for detailed information.)

**Turbo Mode (Available when Power Technology is set to Custom)**

Select Enabled to use the Turbo Mode to boost system performance. The options are **Enabled** and Disabled.

**C1E (Available when Power Technology is set to Custom)**

Select Enabled to enable Enhanced C1 Power State to boost system performance. The options are **Enabled** and Disabled.

**CPU C3 Report (Available when Power Technology is set to Custom)**

Select Enabled to allow the BIOS to report the CPU C3 State (ACPI C2) to the operating system. During the CPU C3 State, the CPU clock generator is turned off. The options are Enabled and **Disabled**.

**CPU C6 Report (Available when Power Technology is set to Custom)**

Select Enabled to allow the BIOS to report the CPU C6 State (ACPI C3) to the operating system. During the CPU C6 State, the power to all cache is turned off. The options are **Enabled** and Disabled.

**CPU C7 Report (Available when Power Technology is set to Custom)**

Select Enabled to allow the BIOS to report the CPU C7 State (ACPI C3) to the operating system. CPU C7 State is a processor-specific low C-State. The options are **Enabled** and Disabled.

**Package C-State limit (Available when Power Technology is set to Custom)**

This feature allows the user to set the limit on the C-State package register. The options are C0, C2, **C6**, and No Limit.

**Energy/Performance Bias**

This setting allows the user to adjust the fan speed based on performance (maximum cooling) or energy efficiency (maximum energy savings). The options are Performance, **Balanced Performance**, Balanced Energy, and Energy Efficient.

**Factory Long Duration Power Limit**

This item displays the power limit set by the manufacturer during which long duration power is maintained. The default setting is **70 Watts**.

**Long Duration Power Limit**

This item displays the power limit set by the user during which long duration power is maintained. The default setting is **0**.

**Factory Long Duration Maintained**

This item displays the period of time set by the manufacturer during which long duration power is maintained. The default setting is **10 s**.

**Long Duration Maintained**

This item displays the period of time during which long duration power is maintained. The default setting is **0**.

**Recommended Short Duration Power**

This item displays the short duration power settings recommended by the manufacturer. The default setting is **1.2 \* Long Duration**.

### Short Duration Power Limit

This item displays the time period during which short duration power is maintained. The default setting is **0**.

## ► Chipset Configuration

### ► North Bridge

This feature allows the user to configure the settings for the Intel North Bridge.

### ► Integrated IO Configuration

#### Intel® VT-d

Select Enabled to enable Intel Virtualization Technology support for Direct I/O VT-d by reporting the I/O device assignments to VWM (Virtual Working Memory) through the DMAR ACPI Tables. This feature offers fully-protected I/O resource-sharing across Intel platforms, providing greater reliability, security, and availability in networking and data-sharing. The options are **Enabled** and Disabled.

#### Ageing Timer Rollover

Select Disabled to allow the BIOS to determine how long the system should wait before reallocating resources to PCI-E devices for data transferring when a deadlock occurs. Select 32 us for the BIOS to wait for 32 us seconds before reallocating system resources for use of PCI-E data transferring when a deadlock occurs. The options are Disabled, 32 us, **128 us**, and 512 us.

#### Data Direct I/O

Select Enabled to enable Intel I/OAT (I/O Acceleration Technology), which significantly reduces CPU overhead by leveraging CPU architectural improvements and freeing the system resource for other tasks. The options are Disabled and **Enabled**.

#### DCA Support

Select Enabled to use Intel's DCA (Direct Cache Access) Technology to improve the efficiency in data transferring. The default setting is **Enabled**. Do not change the default setting.

#### Slot1 Riser Card/Slot2 Riser Card/Slot3 Riser Card/Slot4 Riser Card/ Slot5 Riser Card

These items display the statuses of the riser cards installed in the slots specified.



---

### **IIO 1 PCIe Port Bifurcation Control**

This submenu configures the following IO PCIe Port Bifurcation Control settings for IIO 1 PCIe ports to determine how the available PCI-Express lanes to be distributed between the PCI-Exp. Root Ports.

#### **CPU1 Slot5 PCI-E 3.0 x8 Link Speed**

This feature allows the user to set the PCI-Exp bus speed for the slot specified above. The options are Gen1 (Generation 1), Gen2 and **Gen3**.

#### **CPU1 Slot2 PCI-E 3.0 x16 Link Speed**

This feature allows the user to set the PCI-Exp bus speed for the slot specified above. The options are Gen1 (Generation 1), Gen2 and **Gen3**.

#### **CPU1 Slot1 PCI-E 3.0 x16 Link Speed**

This feature allows the user to set the PCI-Exp bus speed for the slot specified above. The options are Gen1 (Generation 1), Gen2 and **Gen3**.

### **IIO 2 PCIe Port Bifurcation Control**

This submenu configures the following IO PCIe Port Bifurcation Control settings for IIO 2 PCIe ports to determine how the available PCI-Express lanes to be distributed between the PCI-Exp. Root Ports.

#### **CPU2 Slot3 PCI-E 3.0 x16 Link Speed**

This feature allows the user to set the PCI-Exp bus speed for the slot specified above. The options are Gen1 (Generation 1), Gen2 and **Gen3**.

#### **CPU2 Slot4 PCI-E 3.0 x16 Link Speed**

This feature allows the user to set the PCI-Exp bus speed for the slot specified above. The options are Gen1 (Generation 1), Gen2 and **Gen3**.

## **►QPI Configuration**

### **Current QPI Link**

This item displays the current status of the QPI Link.

### **Current QPI Frequency**

This item displays the frequency of the QPI Link.

### **Isoc**

Select Enabled to enable Isynchronous support to meet QoS (Quality of Service) requirements. This feature is especially important for virtualization technology. The options are Enabled and **Disabled**.

### **QPI (Quick Path Interconnect) Link Speed Mode**

Use this feature to select data transfer speed for QPI Link connections. The options are **Fast** and Slow.

### **QPI Link Frequency Select**

Use this feature to select the desired QPI frequency. The options are **Auto**, 6.4 GT/s, 7.2 GT/s, and 8.0 GT/s.

## **►DIMM Configuration**

This section displays the following DIMM information.

### **Current Memory Mode**

This item displays the current memory mode.

### **Current Memory Speed**

This item displays the current memory speed.

### **Mirroring**

This item displays if memory mirroring is supported by the motherboard. Memory mirroring creates a duplicate copy of the data stored in the memory to enhance data security.

### **Sparing**

This item displays if memory sparing is supported by the motherboard. Memory sparing enhances system performance.

## **►DIMM Information**

### **CPU Socket 1 DIMM Information/ CPU Socket 2 DIMM Information**

#### **P1-DIMMA1~ P1-DIMMD2/P2-DIMME1~ P1-DIMMH2**

The statuses of the memory modules detected by the BIOS will be displayed as detected by the BIOS.

### **Memory Mode**

When Independent is selected, all DIMM modules are available to the operating system. When Mirroring is selected, the motherboard maintains two identical copies of all data in the memory for data backup. When Lock Step is selected, the motherboard uses two areas of memory to run the same set of operations in parallel. The options are **Independent**, Mirroring, and Lock Step.

### **DRAM RAPL Mode**

RAPL (Running Average Power Limit) provides mechanisms to enforce power consumption limits on supported processors. The options are DRAM RAPL MODE0 , **DRAM RAPL MODE1**, and Disabled.

### **DDR Speed**

Use this feature to force a DDR3 memory module to run at a frequency other than what is specified by the manufacturer. The options are **Auto**, Force DDR3 800, Force DDR3 1066, Force DDR3 1333, Force DDR3 1600 and Force SPD.

### **Channel Interleaving**

This feature selects from the different channel interleaving methods. The options are **Auto**, 1 Way, 2 Way, 3, Way, and 4 Way.

### **Rank Interleaving**

This feature allows the user to select a rank memory interleaving method. The options are **Auto**, 1 Way, 2 Way, 4, Way, and 8 Way.

### **Patrol Scrub**

Patrol Scrubbing is a process that allows the CPU to correct correctable memory errors detected on a memory module and send the correction to the requestor (the original source). When this item is set to Enabled, the IO hub will read and write back one cache line every 16K cycles, if there is no delay caused by internal processing. By using this method, roughly 64 GB of memory behind the IO hub will be scrubbed every day. The options are **Enabled** and Disabled.

### **Demand Scrub**

Demand Scrubbing is a process that allows the CPU to correct correctable memory errors found on a memory module. When the CPU or I/O issues a demand-read command, and the read data from memory turns out to be a correctable error, then the error is corrected and sent to the requestor (the original source). Memory is updated as well. Select Enabled to use Demand Scrubbing for ECC memory correction. The options are Enabled and **Disabled**.

### **Data Scrambling**

Select Enabled to enable data scrambling to ensure data security and integrity. The options are Disabled and **Enabled**.

### **Device Tagging**

Select Enabled to support device tagging. The options are **Disabled** and Enabled.

### Thermal Throttling

Throttling improves reliability and reduces power consumption in the processor via automatic voltage control during the processor idle state. The options are Disabled and **CLTT** (Closed Loop Thermal Throttling).

## ► South Bridge Configuration

This feature allows the user to configure the settings for the Intel PCH chip.

### PCH Information

This feature displays the following PCH information.

**Name:** This item displays the name of the PCH chip.

**Stepping:** This item displays the status of the PCH stepping.

**USB Devices:** This item displays the USB devices detected by the BIOS.

### All USB Devices

This feature enables all USB ports/devices. The options are Disabled and **Enabled**. (If this item is set to Enabled, EHCI Controller 1 and Controller 2 will appear.)

### EHCI Controller 1/EHCI Controller 2 (Available when All USB Devices is set to Enabled)

Select Enabled to enable EHCI (Enhanced Host Controller Interface) support for Controller 1 or for Controller 2. The options are Disabled and **Enabled**.

### Legacy USB Support (Available when USB Functions is not Disabled)

Select Enabled to support legacy USB devices. Select Auto to disable legacy support if USB devices are not present. Select Disabled to have USB devices available for EFI (Extensive Firmware Interface) applications only. The settings are Disabled, **Enabled** and Auto.

### Port 60/64 Emulation

Select Enabled to enable I/O port 60h/64h emulation support for the legacy USB keyboard so that it can be fully supported by the operating systems that does not recognize a USB device. The options are Disabled and **Enabled**.

### EHCI Hand-Off

This item is for operating systems that do not support Enhanced Host Controller Interface (EHCI) hand-off. When enabled, EHCI ownership change will be claimed by the EHCI driver. The options are **Disabled** and Enabled.

---

## ► SATA Configuration

When this submenu is selected, the AMI BIOS automatically detects the presence of IDE or SATA devices and displays the following items.

**SATA Port0~SATA Port5:** The AMI BIOS displays the status of each SATA port as detected by the BIOS.

### SATA Mode

Use this feature to configure SATA mode for a selected SATA port. The options are Disabled, IDE Mode, **AHCI Mode** and RAID Mode. The following are displayed depending on your selection:

#### IDE Mode

The following items are displayed when IDE Mode is selected:

##### Serial-ATA (SATA) Controller 0~1

Use this feature to activate or deactivate the SATA controller, and set the compatibility mode. The options for SATA Controller 0 are Disabled, Enhanced, and **Compatible**. The options for SATA Controller 1 are Disabled and **Enhanced**.

#### AHCI Mode

The following items are displayed when the AHCI Mode is selected.

##### Aggressive Link Power Management

Select Enabled to enable Aggressive Link Power Management support for Cougar Point B0 stepping and beyond. The options are **Enabled** and Disabled.

##### Port 0~5 Hot Plug

Select Enabled to enable hot-plug support for a particular port, which will allow the user to change a hardware component or device without shutting down the system. The options are **Enabled** and Disabled.

##### Port 0~5 Staggered Spin Up

Select Enabled to enable Staggered Spin-up support to prevent excessive power consumption caused by multiple HDDs spinning-up simultaneously. The options are Enabled and **Disabled**.

#### RAID Mode

The following items are displayed when RAID Mode is selected:

### Port 0-5 Hot Plug

Select Enabled to enable hot-plug support for the particular port. The options are **Enabled** and Disabled.

## ► SCU (Storage Control Unit) Configuration

### Storage Controller Unit

Select Enabled to enable PCH SCU storage devices. The options are Disabled and **Enabled**.

### SCU RAID Option ROM/UEFI

Select Enabled to support the SCU RAID Option ROM support or UEFI support. The options are Disabled and **Enabled**.

**SCU Port 0-SCU Port 3:** The AMI BIOS will automatically detect the presence of onboard SCU devices and display the status of each SCU device as detected.

## ► PCIe/PCI/PnP Configuration

### Launch Storage OPROM Policy

This feature controls how the system executes UEFI (Unified Extensible Firmware Interface) and legacy storage OPROM. Select Legacy Only to boot the system using a legacy storage device installed in a PCI slot. The options are UEFI Only and **Legacy Only**.

### Launch Video OPROM Policy

This feature controls how the system executes UEFI (Unified Extensible Firmware Interface) and legacy video OPROM. Select Legacy Only to boot the system using a legacy video device installed in a PCI slot. The options are UEFI Only and **Legacy Only**.

### PCI Latency Timer

Use this feature to set the latency timer of each PCI device installed on a PCI bus. Select 64 to set the PCI latency to 64 PCI clock cycles. The options are 32, 64, **96**, 128, 160, 192, 224 and 248.

### PERR# Generation

Select Enabled to allow a PCI device to generate a PERR number for a PCI Bus Signal Error Event. The options are Enabled and **Disabled**.

---

### SERR# Generation

Select Enabled to allow a PCI device to generate an SERR number for a PCI Bus Signal Error Event. The options are Enabled and **Disabled**.

### Maximum Payload

Select Auto to allow the system BIOS to automatically set the maximum payload value for a PCI-E device to enhance system performance. The options are **Auto**, 128 Bytes and 256 Bytes.

### Maximum Read Request

Select Auto to allow the system BIOS to automatically set the maximum Read Request size for a PCI-E device to enhance system performance. The options are **Auto**, 128 Bytes, 256 Bytes, 512 Bytes, 1024 Bytes, 2048 Bytes, and 4096 Bytes.

### ASPM Support

This feature allows the user to set the Active State Power Management (ASPM) level for a PCI-E device. Select Auto to allow the system BIOS to automatically set the ASPM level for the system. Select Disabled to disable ASPM support. The options are **Disabled** and Auto.

**Warning:** Enabling ASPM support may cause some PCI-E devices to fail!

### Above 4G Decoding (Available if the system supports 64-bit PCI decoding)

Select Enabled to decode a PCI device that supports 64-bit in the space above 4G Address. The options are Enabled and **Disabled**.

### CPU1 Slot 1 PCI-E 3.0 x16 OPROM/CPU1 Slot 2 PCI-E 3.0 x16 OPROM/CPU2 Slot 3 PCI-E 3.0 x16 OPROM/CPU2 Slot 4 PCI-E 3.0 x16 OPROM/CPU1 Slot 5 PCI-E 3.0 x8 OPROM/PCH Slot 6 PCI-E 2.0 x4 OPROM

Select Enabled to enable Option ROM support to boot the computer using a network device installed on a slot above as specified by the user. The options are **Enabled** and Disabled.

### Onboard LAN Option ROM Select

Select iSCSI to use the iSCSI Option ROM to boot the computer using a network device. Select PXE (Preboot Execution Environment) to use an PXE Option ROM to boot the computer using a network device. The options are **PXE**, iSCSI and FCoE.

### Load Onboard LAN1 Option ROM/Load Onboard LAN2 Option ROM

Select Enabled to enable the onboard LAN1 Option ROM~LAN2 Option ROM. This is to boot the computer using a network device. The default setting for LAN1 Option ROM is **Enabled**, and the default setting for LAN2 Option ROM is **Disabled**.

### VGA Priority

This feature allows the user to select the graphics adapter to be used as the primary boot device. The options are **Onboard**, and **Offboard**.

### Network Stack

Select Enabled enable PXE (Preboot Execution Environment) or UEFI (Unified Extensible Firmware Interface) for network stack support. The options are Enabled and **Disabled**.

## ► Super IO Configuration

**Super IO Chip:** This item displays the Super IO chip used in the motherboard.

## ► Serial Port 1 Configuration/Serial Port 2 Configuration

### Serial Port

Select Enabled to enable a serial port specified by the user. The options are **Enabled** and **Disabled**.

### Device Settings

This item displays the settings of a serial port specified by the user.

### Change Settings

Use this feature to set the optimal Platform Environment Control Interface (PECI) setting for a serial port specified. The default setting is **Auto**, which will allow the AMI BIOS to automatically select the best PECI setting.

### Device Mode

Use this feature to select the desired mode for a serial port specified. The options are **Normal** and **High Speed**.

## ► Serial Port Console Redirection

### COM 1/SOL

These two submenus allow the user to configure the following Console Redirection settings for a COM Port specified by the user.

### Console Redirection

Select Enabled to use a COM Port selected by the user for Console Redirection. The options are Enabled and Disabled. The default setting for COM1 is **Disabled**, and for SOL is **Enabled**.



---

## ► Console Redirection Settings

This feature allows the user to specify how the host computer will exchange data with the client computer, which is the remote computer used by the user.

### Terminal Type

This feature allows the user to select the target terminal emulation type for Console Redirection. Select VT100 to use the ASCII Character set. Select VT100+ to add color and function key support. Select ANSI to use the Extended ASCII Character Set. Select VT-UTF8 to use UTF8 encoding to map Unicode characters into one or more bytes. The options are ANSI, VT100, **VT100+**, and VT-UTF8.

### Bits Per second

Use this feature to set the transmission speed for a serial port used in Console Redirection. Make sure that the same speed is used in the host computer and the client computer. A lower transmission speed may be required for long and busy lines. The options are 9600, 19200, 38400, 57600 and **115200** (bits per second).

### Data Bits

Use this feature to set the data transmission size for Console Redirection. The options are 7 Bits and **8 Bits**.

### Parity

A parity bit can be sent along with regular data bits to detect data transmission errors. Select Even if the parity bit is set to 0, and the number of 1's in data bits is even. Select Odd if the parity bit is set to 0, and the number of 1's in data bits is odd. Select None if you do not want to send a parity bit with your data bits in transmission. Select Mark to add a mark as a parity bit to be sent along with the data bits. Select Space to add a Space as a parity bit to be sent with your data bits. The options are **None**, Even, Odd, Mark and Space.

### Stop Bits

A stop bit indicates the end of a serial data packet. Select 1 Stop Bit for standard serial data communication. Select 2 Stop Bits if slower devices are used. The options are **1** and 2.

### Flow Control

This feature allows the user to set the flow control for Console Redirection to prevent data loss caused by buffer overflow. Send a "Stop" signal to stop sending data when the receiving buffer is full. Send a "Start" signal to start sending data when the receiving buffer is empty. The options are **None** and Hardware RTS/CTS.

### **VT-UTF8 Combo Key Support**

Select Enabled to enable VT-UTF8 Combination Key support for ANSI/VT100 terminals. The options are **Enabled** and Disabled.

### **Recorder Mode**

Select Enabled to capture the data displayed on a terminal and send it as text messages to a remote server. The options are **Disabled** and Enabled.

### **Resolution 100x31**

Select Enabled for extended-terminal resolution support. The options are Disabled and **Enabled**.

### **Legacy OS Redirection Resolution**

Use this feature to select the number of rows and columns used in Console Redirection for legacy OS support. The options are 80x24 and **80x25**.

### **Putty KeyPad**

This feature selects Function Keys and KeyPad settings for Putty, which is a terminal emulator designed for the Windows OS. The options are **VT100**, LINUX, XTERMR6, SC0, ESCN, and VT400.

### **Redirection After BIOS POST**

If **Always Enabled** is selected, Legacy Console Redirection will be enabled for Legacy OS after BIOS POST (Power-On Self Test) is completed. The options are **Always Enabled**, and BootLoader.

## **Serial Port for Out-of-Band Management/Windows Emergency Management Services (EMS)**

### **EMS (Emergency Management Services) Console Redirection (for Out of Band Serial Port Management)**

The submenu allows the user to configure Console Redirection settings to support Out-of-Band Serial Port management.

#### **EMS Console Redirection**

Select Enabled to enable EMS Console Redirection support using an out-of-band serial port. The options are Enabled and **Disabled**.

### **► Console Redirection Settings**

This feature allows the user to specify how the host computer will exchange data with the client computer, which is the remote computer used by the user.

### **Out-of-Band Management Port**

The feature selects a serial port used by the Microsoft Windows Emergency Management Services (EMS) to communicate with a remote server. The options are **COM1** and SOL.

### **Terminal Type**

This feature allows the user to select the target terminal emulation type for Console Redirection. Select VT100 to use the ASCII character set. Select VT100+ to add color and function key support. Select ANSI to use the extended ASCII character set. Select VT-UTF8 to use UTF8 encoding to map Unicode characters into one or more bytes. The options are ANSI, VT100, **VT100+**, and VT-UTF8.

### **Bits Per Second**

This item sets the transmission speed for a serial port used in Console Redirection. Make sure that the same speed is used in the host computer and the client computer. A lower transmission speed may be required for long and busy lines. The options are 9600, 19200, 57600, and **115200** (bits per second).

### **Flow Control**

This feature allows the user to set the flow control for Console Redirection to prevent data loss caused by buffer overflow. Send a "Stop" signal to stop sending data when the receiving buffer is full. Send a "Start" signal to start sending data when the receiving buffer is empty. The options are **None**, Hardware RTS/CTS, and Software Xon/Xoff.

### **Data Bits, Parity, Stop Bits**

The status of these features is displayed.

## **► ACPI Settings**

Use this feature to configure Advanced Configuration and Power Interface (ACPI) power management settings for your system.

### **ACPI Sleep State**

Use this feature to select the ACPI State when the system is in sleep mode. Select S1 (CPU\_Stop\_Clock) to erase all CPU caches and stop executing instructions. Power to the CPU(s) and RAM is maintained, but RAM is refreshed. Select Suspend Disabled to use power-reduced mode. Power will only be supplied to limited components (such as RAMs) to maintain the most critical functions of the system. The options are **S1 (CPU\_Stop\_Clock)** and Suspend Disabled.

### **NUMA (NON-Uniform Memory Access)**

This feature enables the Non-Uniform Memory Access ACPI support. The options are **Enabled** and Disabled.

### **High Precision Event Timer**

Select Enabled to activate the High Precision Event Timer (HPET) that produces periodic interrupts at a much higher frequency than a Real-time Clock (RTC) does in synchronizing multimedia streams, providing smooth playback, reducing the dependency on other timestamp calculation devices, such as an x86 RDTSC Instruction embedded in the CPU. The High Performance Event Timer is used to replace the 8254 Programmable Interval Timer. The options are **Enabled** and Disabled.

## **► Trusted Computing (Available when a TPM device is detected by the BIOS)**

### **Configuration**

#### **TPM Support**

Select Enabled on this item and enable the TPM jumper on the motherboard to enable TPM support to improve data integrity and network security. The options are **Enabled** and Disabled.

#### **TPM State**

Select Enabled to enable TPM security settings to improve data integrity and network security. The options are **Disabled** and Enabled.

**Pending Operation:** This item displays the status of a pending operation.

**Current Status Information:** This item displays the information regarding the current TPM status.

### **TPM Enable Status**

This item displays the status of TPM Support to indicate if TPM is currently enabled or disabled.

### **TPM Active Status**

This item displays the status of TPM Support to indicate if TPM is currently active or deactivated.

### **TPM Owner Status**

This item displays the status of TPM Ownership.

## ► Intel TXT (LT-SX) Configuration

### Intel TXT (LT-SX) Hardware Support

This feature indicates if the following hardware components support the Intel Trusted Execution Technology.

**CPU:** TXT (Trusted Execution Technology) Feature

**Chipset:** TXT (Trusted Execution Technology) Feature

### Intel TXT (LT-SX) Configuration

This feature displays the following TXT configuration setting.

**TXT (LT-SX) Support:** This item indicates if the Intel TXT support is enabled or disabled.

### Intel TXT (LT-SX) Dependencies

This feature displays the features that need to be enabled for the Intel Trusted Execution Technology to work properly in the system.

**VT-d Support:** Intel Virtualization Technology with Direct I/O support

**VT Support:** Intel Virtualization Technology support

**TPM Support:** Trusted Platform support

**TPM State:** Trusted Platform state

## ► ME Subsystem

### ME Subsystem Configuration

This feature displays the following ME Subsystem Configuration settings.

- **ME BIOS Interface Version**
- **ME Version**

## 7-4 Event Logs

Select the Event Logs tab to access the following submenu items.

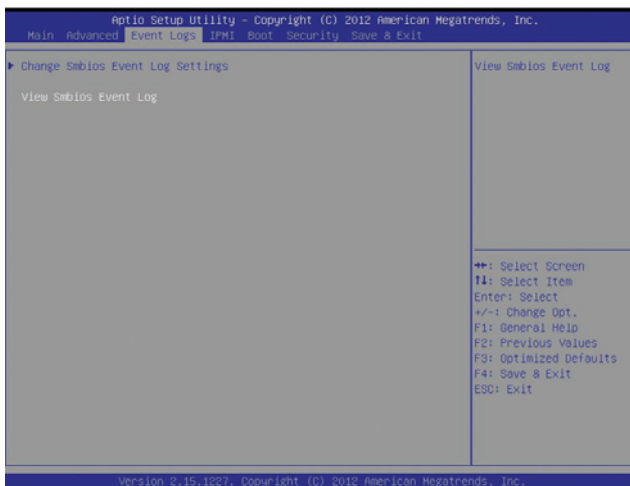

### ►Change SMBIOS Event Log Settings

This feature allows the user to configure SMBIOS Event settings.

#### Enabling/Disabling Options

##### SMBIOS Event Log

Select Enabled to enable SMBIOS (System Management BIOS) Event Logging during system boot. The options are **Enabled** and Disabled.

##### Runtime Error Logging Support

Select Enabled to support Runtime Error Logging. The options are **Enabled** and Disabled.

##### Memory Correctable Error Threshold

This feature allows the user to enter the threshold value for correctable memory errors. The default setting is **10**.

##### PCI Error Logging Support

Select Enabled to support error event logging for PCI slots. The options are Enabled and **Disabled**.

## Erasing Settings

### Erase Event Log

Select Enabled to erase the SMBIOS (System Management BIOS) Event Log, which is completed before a event logging is initialized upon system reboot. The options are **No** and Yes.

### When Log is Full

Select Erase Immediately to immediately erase SMBIOS error event logs that exceed the limit when the SMBIOS event log is full. Select Do Nothing for the system to do nothing when the SMBIOS event log is full. The options are **Do Nothing** and Erase Immediately.

## SMBIOS Event Log Standard Settings

### Log System Boot Event

Select Enabled to log system boot events. The options are **Disabled** and Enabled.

### MECI (Multiple Event Count Increment)

Enter the increment value for the multiple event counter. Enter a number between 1 to 255. The default setting is **1**.

### METW (Multiple Event Count Time Window)

This item allows the user to decide how long (in minutes) should the multiple event counter wait before generating a new event log. Enter a number between 0 to 99. The default setting is **60**.

## 7-5 IPMI

Select the IPMI (Intelligent Platform Management Interface) tab to access the following submenu items.

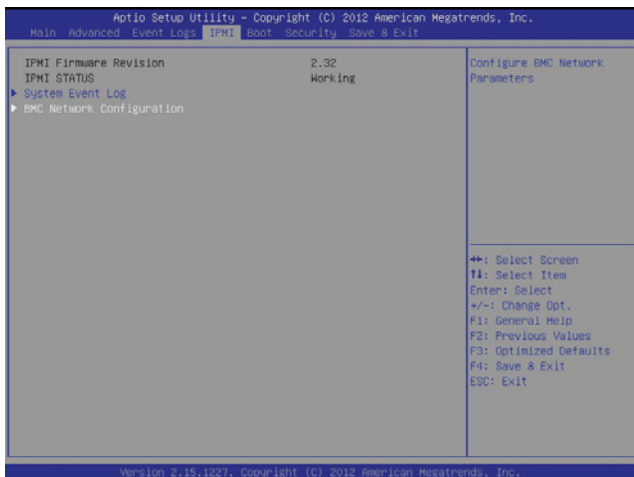

### IPMI Firmware Revision

This item indicates the IPMI firmware revision used in your system.

### IPMI Status

This item indicates the status of the IPMI firmware installed in your system.

## ►System Event Log

### Enabling/Disabling Options

#### SEL Components

Select Enabled for all system event logging at bootup. The options are **Enabled** and Disabled.

#### Erasing Settings

##### Erase SEL

Select Yes, On next reset to erase all system event logs upon next system reboot.  
 Select Yes, On every reset to erase all system event logs upon each system reboot.  
 Select No to keep all system event logs after each system reboot. The options are **No**, Yes, On next reset, and Yes, On every reset.



### When SEL is Full

This feature allows the user to decide what the BIOS should do when the system event log is full. Select Erase Immediately to erase all events in the log when the system event log is full. The options are **Do Nothing** and Erase Immediately.

**Note:** After making changes on a setting, be sure to reboot the system for the changes to take effect.

## ► BMC Network Configuration

**LAN Channel 1:** This feature allows the user to configure the settings for LAN1 Port.

### IPMI LAN Selection

This feature allows the user to configure the IPMI LAN setting. The default setting is **Failover**.

### IPMI Network Link Status

This feature displays the status of IPMI Network Link connections. The default setting is **Dedicated LAN**.

### Update IPMI LAN Configuration

This feature allows the user to decide if the BIOS should configure the IPMI setting at next system boot. The options are **No** and Yes. If the option is set to Yes, the user is allow to configure the IPMI settings at next system boot:

### Configuration Address Source

This feature allows the user to select the source of the IP address for this computer. If Static is selected, you will need to know the IP address of this computer and enter it to the system manually in the field. If DHCP is selected, the BIOS will search for a DHCP (Dynamic Host Configuration Protocol) server in the network that is attached to and request the next available IP address for this computer. The options are **DHCP** and Static. The following items are assigned IP addresses automatically if DHCP is selected, or can be configured manually if Static is selected.

### Station IP Address

This item displays the Station IP address for this computer. This should be in decimal and in dotted quad form (i.e., 192.168.10.253).

### Subnet Mask

This item displays the sub-network that this computer belongs to. The value of each three-digit number separated by dots should not exceed 255.

### Station MAC Address

This item displays the Station MAC address for this computer. Mac addresses are 6 two-digit hexadecimal numbers.

### Gateway IP Address

This item displays the Gateway IP address for this computer. This should be in decimal and in dotted quad form (i.e., 192.168.10.253).

## 7-6 Boot

This submenu allows the user to configure the following boot settings for the system.



### Set Boot Priority

This option prioritizes the order of bootable devices that the system to boot from. Press [ENTER] on each entry from top to bottom to select devices.

- 1st Boot Device
- 2nd Boot Device
- 3rd Boot Device
- 4th Boot Device
- 5th Boot Device
- 6th Boot Device

### ► Delete Boot Option

This feature allows the user to select a previously defined boot device to delete from the boot device list so that this device can no longer be used for system boot.

### ► Network Device BBS Priorities

This feature allows the user to specify which Network devices are boot devices.

- 1st Boot Device
- 2nd Boot Device

### ► UEFI Boot Drive BBS Priorities

This feature allows the user to specify which UEFI devices are boot devices.

- 1st Boot Device

## 7-7 Security

This menu allows the user to configure the following security settings for the system.

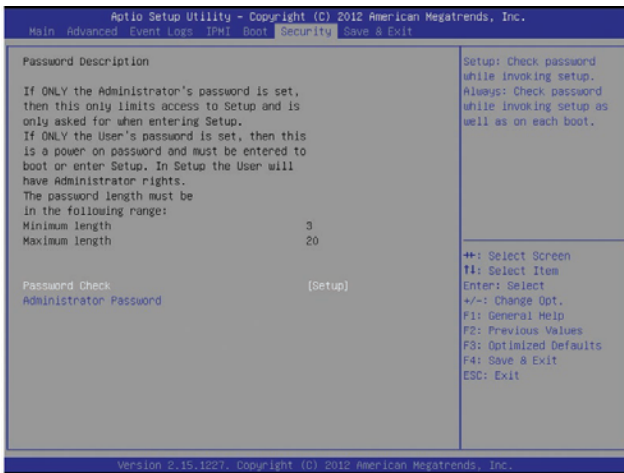

### Password Check

Select Setup for the system to check for a password when the system enters the AMI Setup utility. Select Always for the system to check for a password at each system boot. The options are **Setup** and Always.

### **Administrator Password**

Use this feature to set the Administrator Password which is required to enter the BIOS setup utility. The length of the password should be from 3 characters to 8 characters long.

## 7-8 Save & Exit

This submenu allows the user to configure the Save and Exit settings for the system.

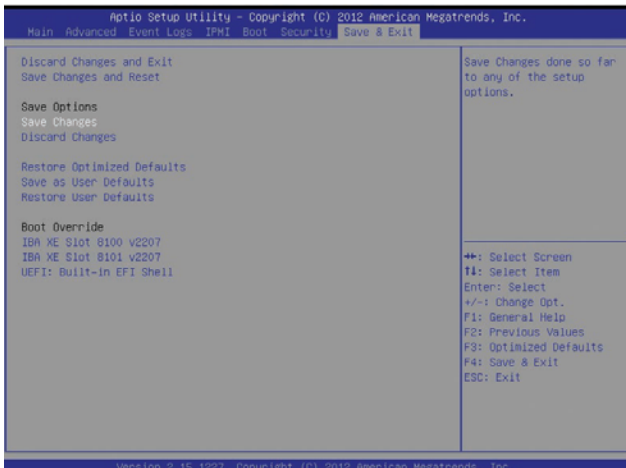

### Discard Changes and Exit

Select this option to exit the BIOS Setup without making any permanent changes to the system configuration, and reboot the computer. Select Discard Changes and Exit, and press <Enter>. When the dialog box appears, asking you if you want to exit the BIOS setup without saving, click **Yes** to quit BIOS without saving the changes, or click No to quit the BIOS and save changes.

### Save Changes and Reset

When you have completed the system configuration changes, select this option to save the changes and reboot the computer so that the new system configuration settings can take effect. Select Save Changes and Exit, and press <Enter>. When the dialog box appears, asking you if you want to exit the BIOS setup without saving, click **Yes** to quit BIOS without saving the changes, or click No to quit the BIOS and save changes.

### Save Options

#### Save Changes

Select this option and press <Enter> to save all changes you've done so far and return to the AMI BIOS utility Program. When the dialog box appears, asking you if you want to save configuration, click **Yes** to save the changes, or click No to return to the BIOS without making changes.

**Discard Changes**

Select this feature and press <Enter> to discard all the changes and return to the BIOS setup. When the dialog box appears, asking you if you want to load previous values, click **Yes** to load the values previous saved, or click No to keep the changes you've made so far.

**Restore Optimized Defaults**

Select this feature and press <Enter> to load the optimized default settings that help optimize system performance. When the dialog box appears, asking you if you want to load optimized defaults, click **Yes** to load the optimized default settings, or click No to abandon optimized defaults.

**Save as User Defaults**

Select this feature and press <Enter> to save the current settings as the user's defaults. When the dialog box appears, asking you if you want to save values as user's defaults, click **Yes** to save the current values as user's default settings, or click No to keep the defaults previously saved as the user's defaults.

**Restore User Defaults**

Select this feature and press <Enter> to load the user's defaults previously saved in the system. When the dialog box appears, asking you if you want to restore user's defaults, click **Yes** to restore the user's defaults previously saved in the system, or click No to abandon the user's defaults that were previously saved.

**Boot Override**

This feature allows the user to override the Boot Option Priorities setting in the Boot menu, and instead boot the system with one of the listed devices.

## Appendix A

### BIOS Error Beep Codes

During the POST (Power-On Self-Test) routines, which are performed at each system boot, errors may occur.

**Non-fatal errors** are those which, in most cases, allow the system to continue to boot. The error messages normally appear on the screen.

**Fatal errors** will not allow the system to continue with bootup procedure. If a fatal error occurs, you should consult with your system manufacturer for possible repairs.

These fatal errors are usually communicated through a series of audible beeps. The numbers on the fatal error list correspond to the number of beeps for the corresponding error.

BIOS Error Beep Codes		
Beep Code/LED	Error Message	Description
1 beep	Refresh	Ready to boot
5 short beeps + 1 long beep	Memory error	No memory detected in the system
5 beeps	No Con-In or No Con-Out devices	Con-In: USB or PS/2 keyboard, PCI or Serial Console Redirection, IPMI KVM or SOL Con-Out: Video Controller, PCI or Serial Console Redirection, IPMI SOL
1 beep per device	Refresh	1 beep for each USB device
X9 IPMI Error Codes		
1 Continuous Beep	System OH	System Overheat

## Notes



# Appendix B

## System Specifications

### Processors

Two Intel Xeon E5-2600 series processors in LGA 2011 sockets

Note: Please refer to our web site for a complete listing of supported processors.

### Chipset

Intel C602

### BIOS

128Mb SPI Flash EEPROM with AMI® BIOS

### Memory Capacity

Sixteen DIMM sockets supporting up to 512 GB of registered ECC DDR3-1600/1333/1066 MHz RDIMMs or 128 GB of ECC/non-ECC UDIMMs

Note: See the memory section in Chapter 5 for details.

### GPUs (Graphics Processing Units)

A total of three GPUs are supported (true PCI-E 3.0 x16 signal)

### SATA Controller

Intel on-chip controller for 10 SATA ports (RAID 0, 1, 5 and 10)

### Drive Bays

Four 2.5" hot-swap drive bays to house SATA drives

### Expansion Slots

Four PCI-Express 3.0 x16 slots to support three double-width GPU cards. Additional slot supports one low-profile PCI-Express 3.0 x8 (in x16 slot)

### Serverboard

X9DRG-HF+II/X9DRG-HFT+II (proprietary ATX form factor)

Dimensions: 19.7" x 9.2" (500.4 x 233.7 mm)

## Chassis

SC118GH-R1K66B (1U rackmount)

Dimensions: (WxHxD) 17.2 x 1.7 x 30.6 in. (437 x 43 x 777 mm)

## System Cooling

Ten sets of 4-cm counter-rotating cooling fans (fan speed controlled by IPMI)

## System Input Requirements

AC Input Voltage: 100-240 VAC

Rated Input Current: 1000W: 100-127V/12.9A, 1600W: 200-240V/9.5A

Rated Input Frequency: 50-60 Hz

## Power Supply

Rated Output Power: 1000W/1600W (Part# PWS-1K66P-1R)

Rated Output Voltages: 1000W: +12V (82A), +12Vsb (2A), 1600W: +12V (132A), +12Vsb (2A)

## Operating Environment

Operating Temperature: 10° to 35° C (50° to 95° F)

Non-Operating Temperature: -40° to 70° C (-40° to 158° F)

Operating Relative Humidity: 8% to 90% (non-condensing)

Non-Operating Relative Humidity: 5 to 95% (non-condensing)

## Regulatory Compliance

Electromagnetic Emissions: FCC Class A, EN 55022 Class A, EN 61000-3-2/-3-3, CISPR 22 Class A

Electromagnetic Immunity: EN 55024/CISPR 24, (EN 61000-4-2, EN 61000-4-3, EN 61000-4-4, EN 61000-4-5, EN 61000-4-6, EN 61000-4-8, EN 61000-4-11)

Safety: CSA/EN/IEC/UL 60950-1 Compliant, UL or CSA Listed (USA and Canada), CE Marking (Europe)

California Best Management Practices Regulations for Perchlorate Materials: This Perchlorate warning applies only to products containing CR (Manganese Dioxide) Lithium coin cells. "Perchlorate Material-special handling may apply. See [www.dtsc.ca.gov/hazardouswaste/perchlorate](http://www.dtsc.ca.gov/hazardouswaste/perchlorate)"

(continued from front)

The products sold by Supermicro are not intended for and will not be used in life support systems, medical equipment, nuclear facilities or systems, aircraft, aircraft devices, aircraft/emergency communication devices or other critical systems whose failure to perform be reasonably expected to result in significant injury or loss of life or catastrophic property damage. Accordingly, Supermicro disclaims any and all liability, and should buyer use or sell such products for use in such ultra-hazardous applications, it does so entirely at its own risk. Furthermore, buyer agrees to fully indemnify, defend and hold Supermicro harmless for and against any and all claims, demands, actions, litigation, and proceedings of any kind arising out of or related to such ultra-hazardous use or sale.

## Notes